

Part list Flamingo Rope Pump PTP2011

- Frame, wheel, handel, pump -

drawing name	drawing nr	part nr.	number	part name	material or semi manufacture	dimension in mm	remarks
wheel	PTP2011/1	1.01	2	rubber wheel	14" car tire		from one tire
wheel parts	PTP2011/1/1	1.02	6	tire clamp	pipe class-A 1"	25 long	pipe cut in halve
wheel	PTP2011/1	1.03	6	spoke	reinforcing bar Ø10	153 long	
wheel parts	PTP2011/1/1	1.04	1	wheel hub	pipe class-A 1"	80 long	
wheel parts	PTP2011/1/1	1.05	2	nut	nut M10		
wheel	PTP2011/1	1.06	2	bolt	bolt M10*20		
handle	PTP2011/2	2.01	1	handle wheel side	pipe class-A 3/4"	360 long	
handle	PTP2011/2	2.02	1	handle eccentric	pipe class-A 3/4"	241 long	
handle	PTP2011/2	2.03	1	handle grip	pipe class-A 3/4"	276 long	
handle	PTP2011/2	2.04	3	ring	pipe class-A 1"	7 long	
handle	PTP2011/2	2.05	1	grip	PVC-tube Ø32*1.8	230 long	thin walled
anchor bracket	PTP2011/3/4a	3.01	1	post	pipe class-A 1¼"	985 long	
bushing	PTP2011/3/1	3.11	1	bushing	pipe class-A 1"	250 long	
bushing	PTP2011/3/1	3.12	1	end strip	strip 3 mm thick	50*7	
bushing	PTP2011/3/1	3.13	1	locking needle	2" nut	45 long	remove head and tip
cover brackets	PTP2011/3/2	3.21	2	horizontal bracket	pipe class-A 1/2"	345 long	
cover brackets	PTP2011/3/2	3.22	1	vertical bracket	pipe class-A 1/2"	354 long	
pump support parts	PTP2011/3/3/1	3.31	1	pump support arm	pipe class-A 3/4"	203 long	
pump support parts	PTP2011/3/3/1	3.32	1	fixed pump clamp	strip 30*3	130 long	
pump support parts	PTP2011/3/3/1	3.33	1	removable pump clamp	strip 30*3	125 long	
pump support	PTP2011/3/3	3.34	1	nut	nut M10		
pump support	PTP2011/3/3	3.35	1	washer	washer M10		
pump support	PTP2011/3/3	3.36	1	bolt	bolt M10*25		
pump support parts	PTP2011/3/3/1	3.37	1	return tube clamp	galva sheet 0.7 dik	195*30	
anchor bracket	PTP2011/3/4	3.41	2	anchor bracket	reinforcing bar Ø10	290 long	
cover sheet	PTP2011/4/1	4.11	1	cover sheet	galva. sheet 0.7 dik	200*1000	
cover	PTP2011/4	4.13	4	pop rivet	pop rivet Ø4*10		
cover	PTP2011/4	4.12	8	pop rivet	pop rivet Ø3*8		
return tube	PTP2011/5/1	5.11	1	return tube	PVC-tube Ø40*1,8 *	620 long	diameter one size bigger than the rising main
return tube	PTP2011/5/1	5.12	1	bore hole cover	end cap for borehole		
pump assembly	PTP2011/5	5.21	1	PVC T-joint	PVC T-joint 50*50*50		
pump assembly	PTP2011/5	5.22	1	top tube	PVC-tube Ø50*1,8	313 long	
pump assembly	PTP2011/5	5.23	1	outlet tube	PVC-tube Ø50*1,8	150 long	
pump assembly	PTP2011/5	5.24	1	coupling tube	PVC-tube Ø50*1,8	117 long	
pump assembly	PTP2011/5	5.25	*	reducer 25-48.2	PVC (various pipe dimentions)	30 long	
pump assembly	PTP2011/5	5.26	*	rising main	PVC-tube Ø25*1 *	* long	diameter and length depends on rising height
return inlet	PTP2011/5/3	5.31	1	inlet guide	PVC-tube Ø19	670 long	PVC electric installation pipe
return inlet	PTP2011/5/3	5.32	1	rope guide	PVC-tube Ø32*1,8	79 long	
		5.41	1	rope	twisted polypropylene rope Ø4	* long	
		5.42	*	pistons	rubber Ø*		made from tire sidewall
Optional: Triangle base for well cover mounting							
anchor base	PTP2011b/3/4	3.01	1	post	pipe class A 1¼"	684 long	replaces part 3.01 (post) from PTP2011/3/4a
anchor base	PTP2011b/3/4	3.42	3	anchoring bar	reinforcing bar Ø10	200 long	part 3.41 (anchor bracket) from drawing PTP2011/3/4a void
anchor base	PTP2011b/3/4	3.43	3	anchor support	pipe class-A 1/2"	255 long	
anchor base	PTP2011b/3/4	3.44	1	anchor triangle	reinforcing bar Ø10	1130 long	

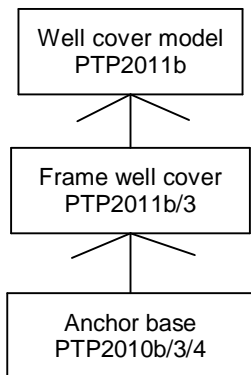
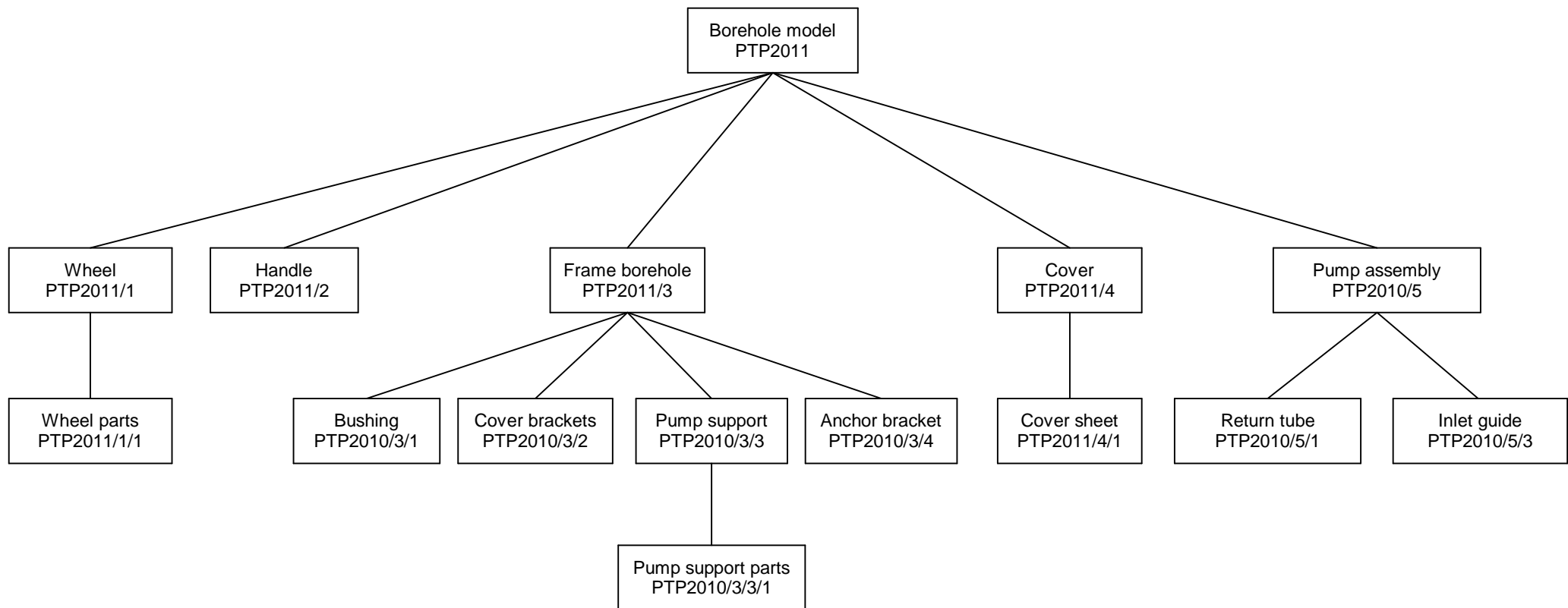

Optional: The rope pump can also be mounted on a well cover. Therefore is a wider base needed. There are three replacement drawings for this mode indicated with an additional "b" in the drawing number.

Part nr.	Number	Part name	Material or semi manufacture	Dimension in mm	Remarks
Project: Flamingo rope pump			Drawn by: Freddy	Date: 13-10-2011	
Drawing: Drawing overview			Checked by: -	Part of: PTP2011	
Scale:			Dimensions in mm	Drawing nr: -	
				A4	



Werkgroep OntwikkelingsTechnieken
www.wot.utwente.nl



Universiteit Twente
de ondernemende universiteit

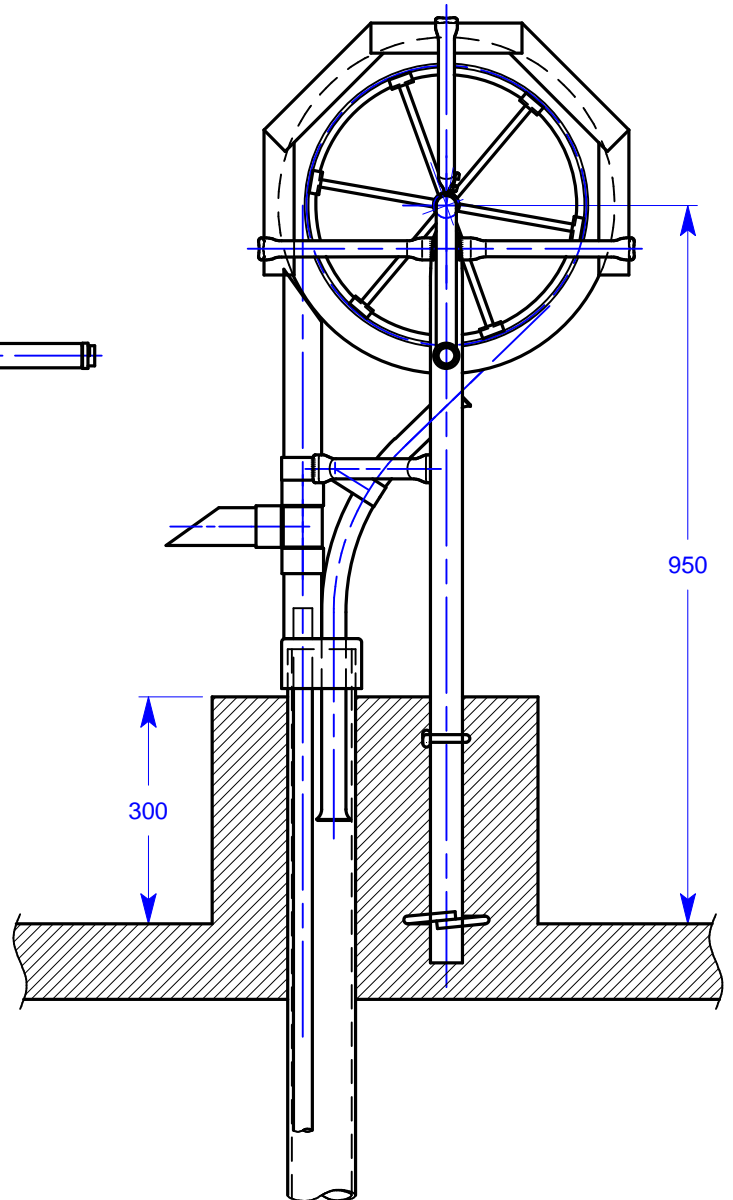
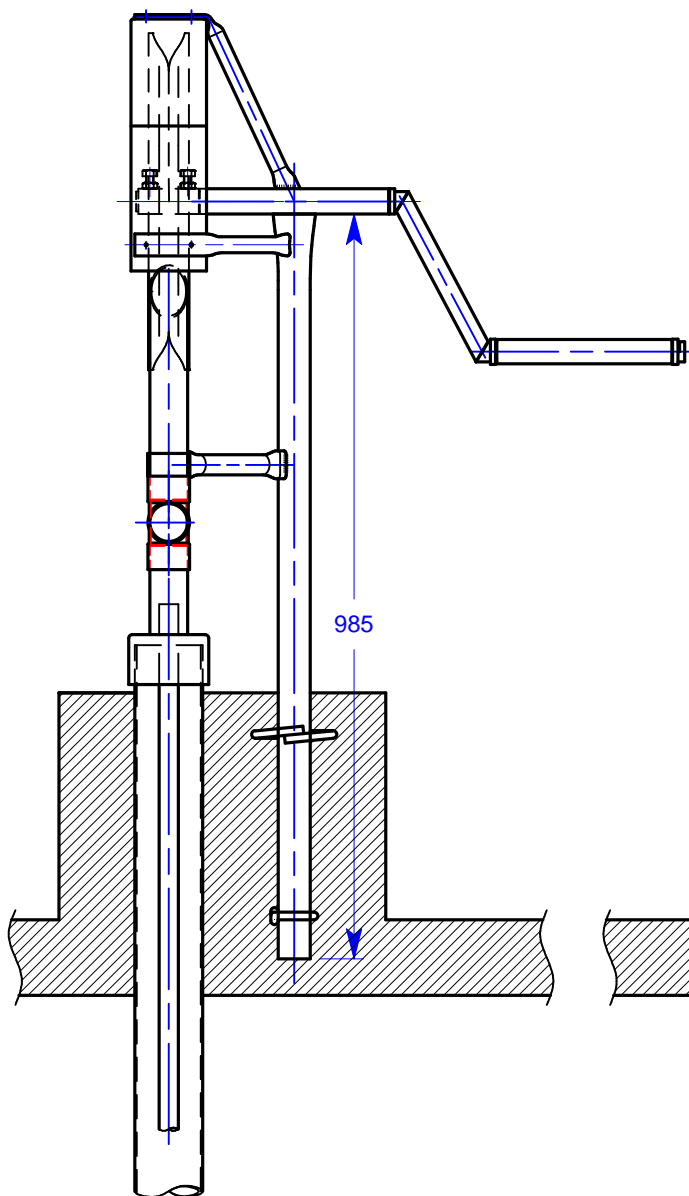
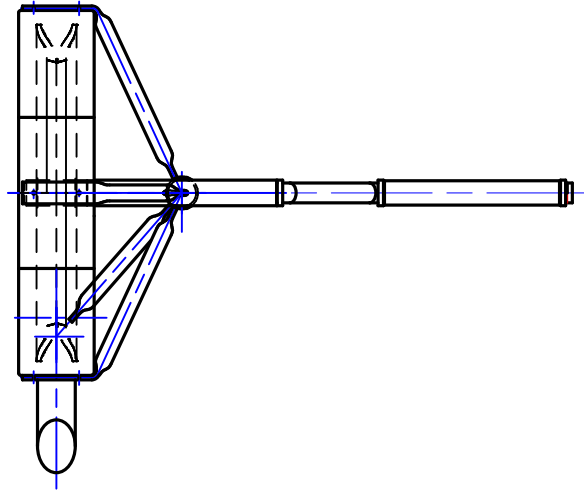

Part nr.	Num ber	Part name	Material or semi manufacture	Dimension in mm	Remarks
Project: Flamingo rope pump			Drawn by: Freddy	Date: 23-09-2011	
Drawing: Borehole model			Checked by: -		
			Part of: -		
			Drawing nr: PTP2011		
Scale: 1:10			Dimensions in mm	A4	
WOT			Werkgroep OntwikkelingsTechnieken www.wot.utwente.nl		Universiteit Twente <i>de ondernemende universiteit</i>

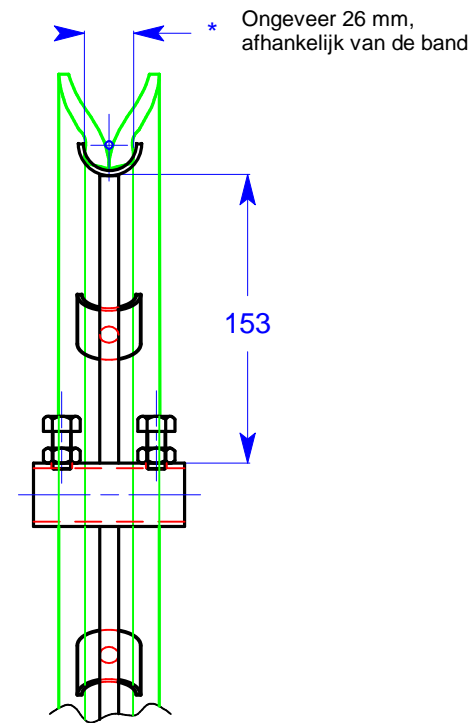
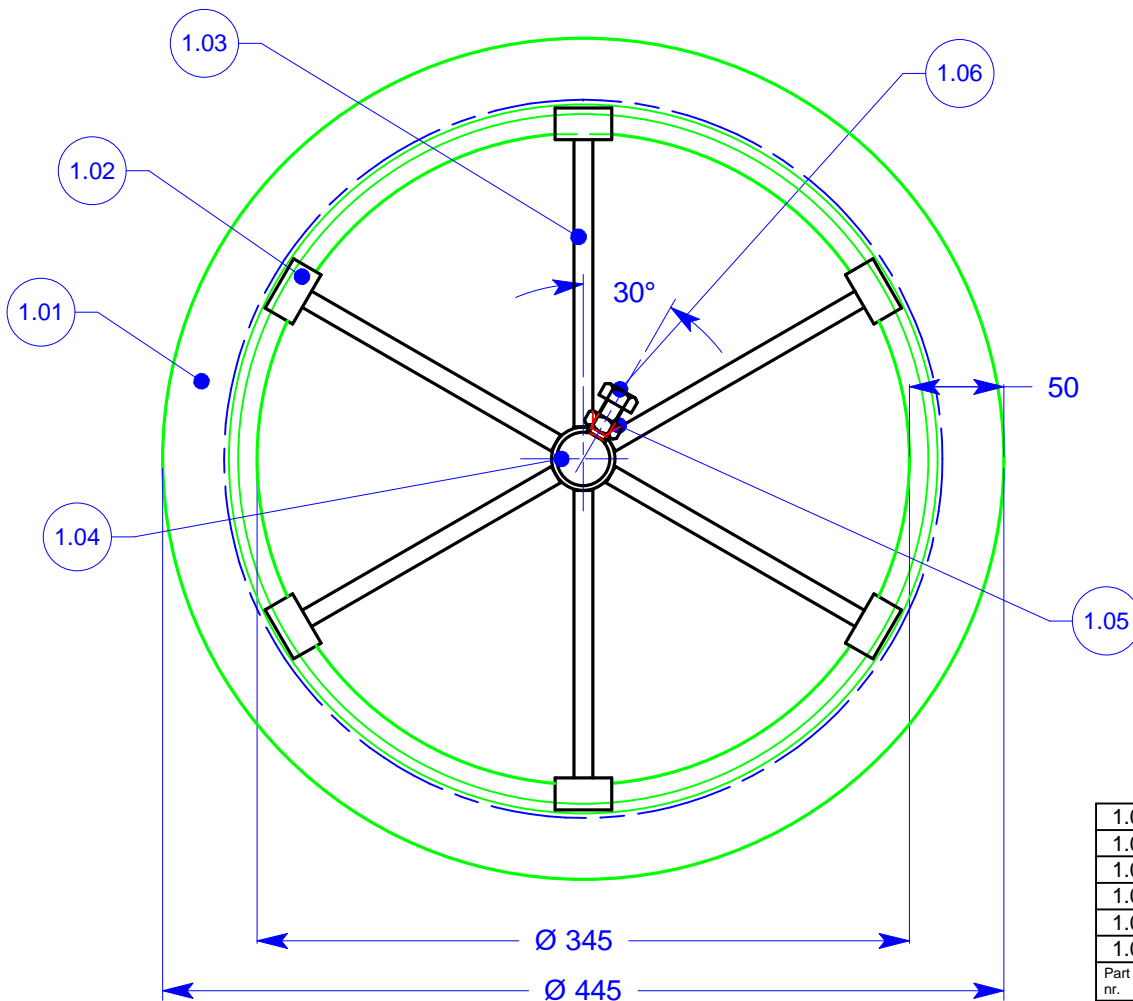

1.06	2	bolt	bolt M10*20		
1.05	2	nut			see PTP2011/1/1
1.04	1	wheel hub			see PTP2011/1/1
1.03	6	spoke	reinforcing bar Ø10	154 long	
1.02	6	tire clamp			see PTP2011/1/1
1.01	2	rubber wheel	14" car tire		cut out of one tire
Part nr.	Number	Part name	Material or semi manufacture	Dimension in mm	Remarks
Project: Flamingo rope pump			Drawn by: Freddy	Date: 04-10-2011	
Drawing: Wheel			Checked by: -		
			Part of: PTP2011		
			Drawing nr: PTP2011/1		
Scale:	1:4		Dimensions in mm	A4	

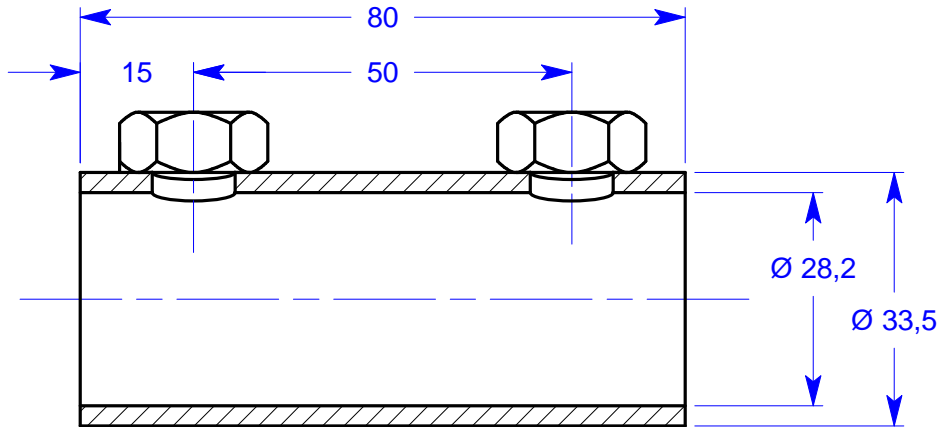
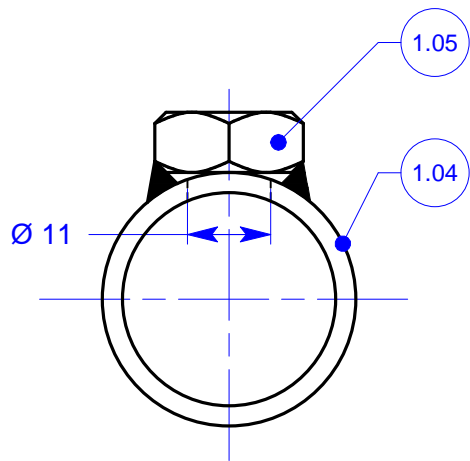

1.02

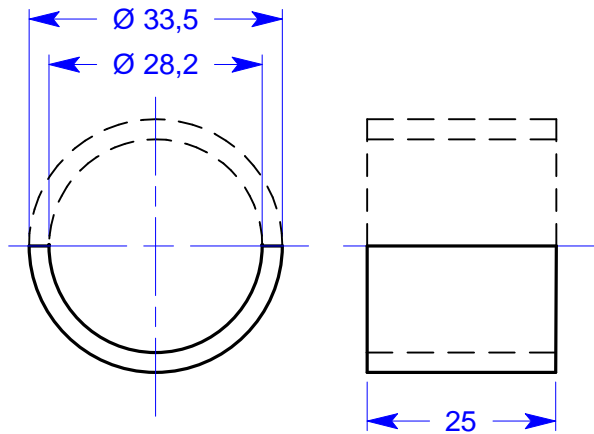

1.05	2	nut	nut M10		
1.04	1	wheel hub	pipe class-A 1"	80 long	
1.02	6	wheel clamp	pipe class-A 1"	25 long	cut ring in halve
Part nr.	Number	Part name	Material or semi manufacture	Dimension in mm	Remarks
Project: Flamingo rope pump			Drawn by: Freddy	Date: 05-10-2011	
Drawing: Wheel parts			Checked by: -	Part of: PTP2011/1	
Scale: 1:1			Drawing nr: PTP2011/1/1		A4



Werkgroep OntwikkelingsTechnieken
www.wot.utwente.nl



Universiteit Twente
de ondernemende universiteit

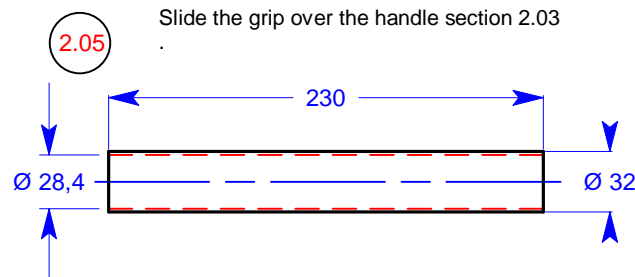
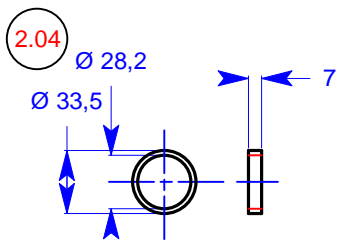
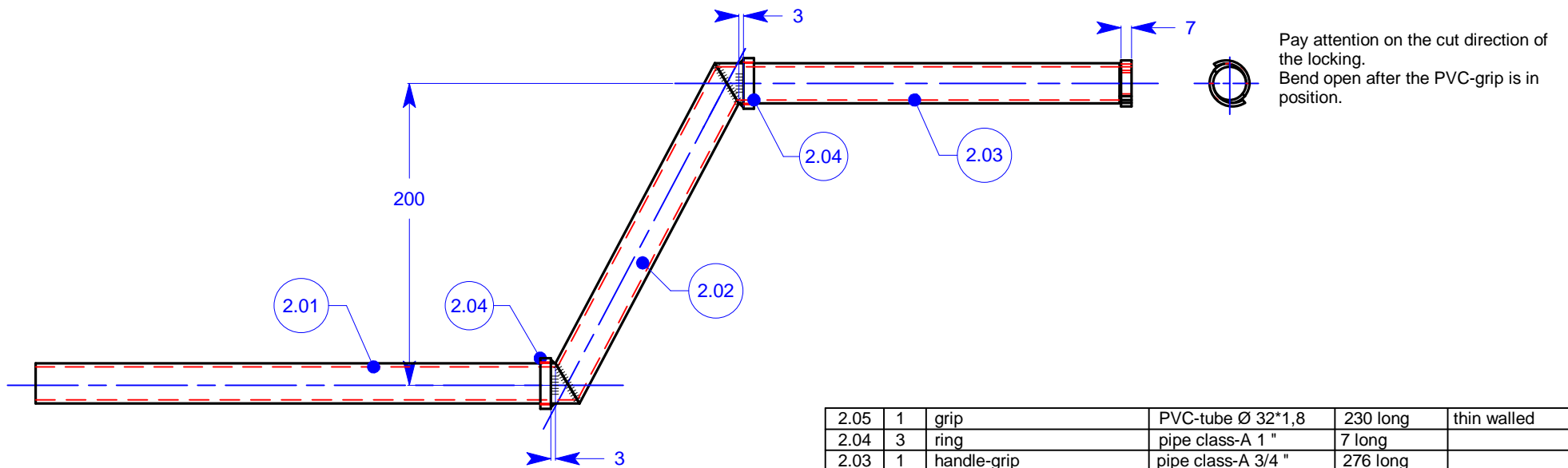
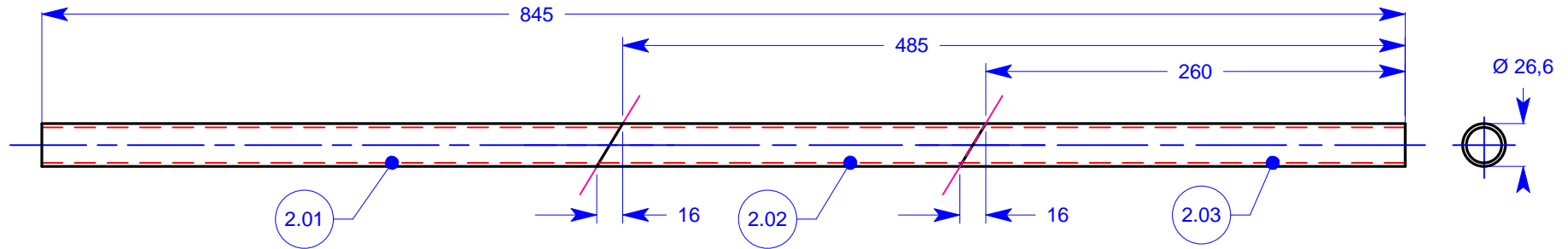

2.05	1	grip	PVC-tube Ø 32*1,8	230 long	thin walled
2.04	3	ring	pipe class-A 1 "	7 long	
2.03	1	handle-grip	pipe class-A 3/4 "	276 long	
2.02	1	handle-eccentric	pipe class-A 3/4 "	241 long	
2.01	1	handle-wheel	pipe class-A 3/4 "	360 long	
2.0	1	handlel	pipe class-A 3/4 "	845 long	
Part nr.	Num ber	Part name	Material or semi manufacture	Dimension in mm	Remarks
Project: Flamingo rope pump			Drawn by: Freddy	Date: 10-11-2011	
Drawing: Handle			Checked by: -	Part of: PTP2011/	
			Drawing nr: PTP2011/2		
Scale: 1:4		Dimensions in mm	A4		

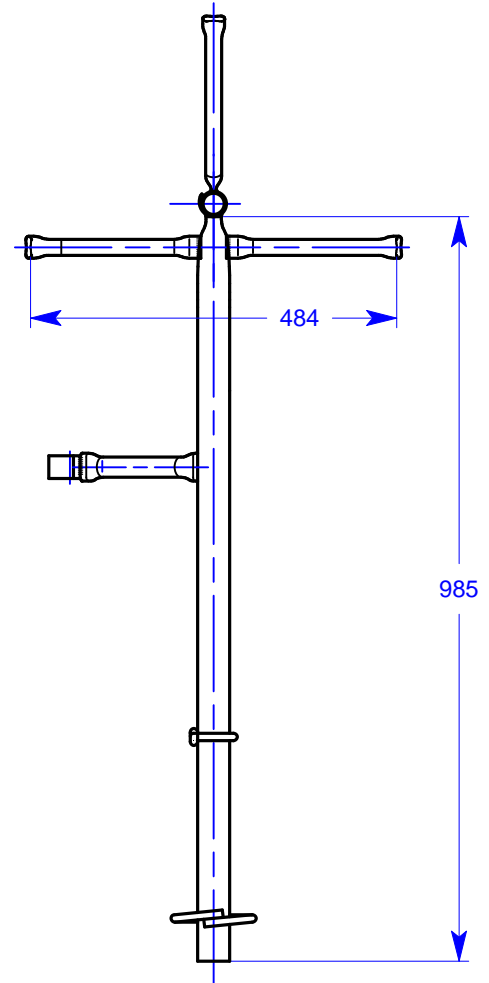
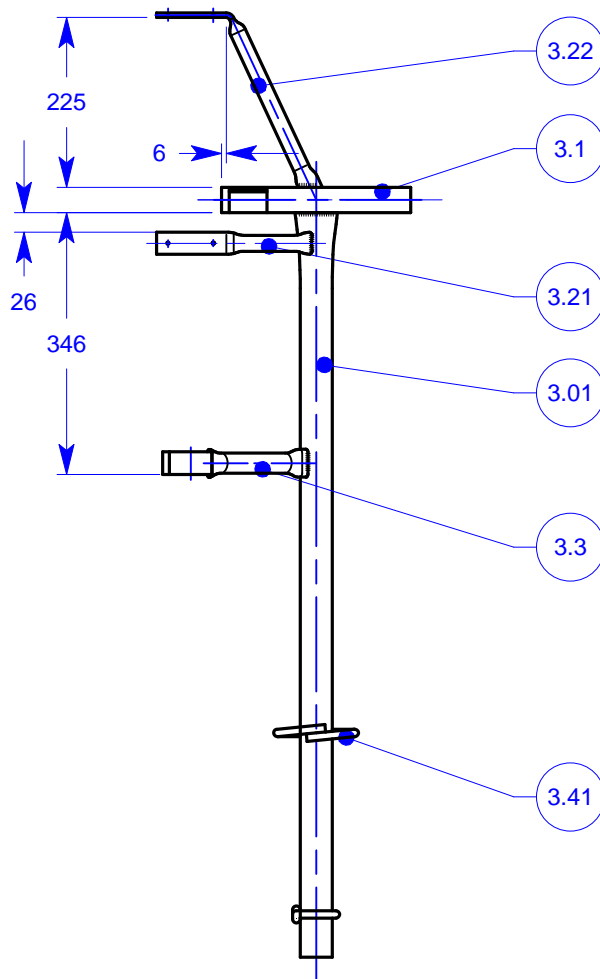
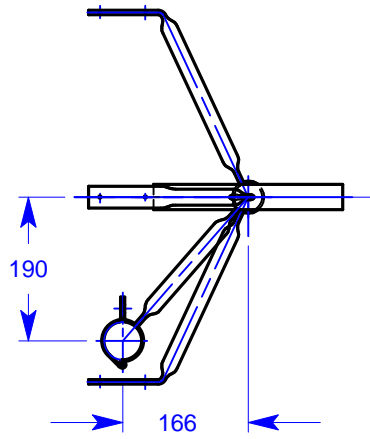

3.41	2	anchor bracket			see PTP2011/3/4
3.3	1	pump support			see PTP2011/3/3
3.22	1	vertical bracket			see PTP2011/3/2
3.21	2	horizontal bracket			see PTP2011/3/2
3.1	1	bushing			see PTP2011/3/1
3.01	1	post			see PTP2011/3/4
Part nr.	Number	Part name	Material or semi manufacture	Dimension in mm	Remarks
Project: Flamingo rope pump			Drawn by: Freddy	Date: 22-09-2011	
Drawing: Frame borehole			Checked by: -		
			Part of: PTP2011		
			Drawing nr: PTP2011/3		
Scale: 1:10		Dimensions in mm			
					A4

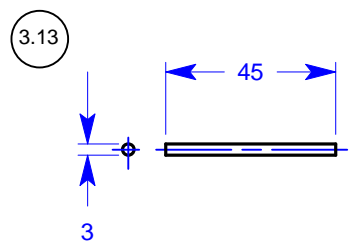
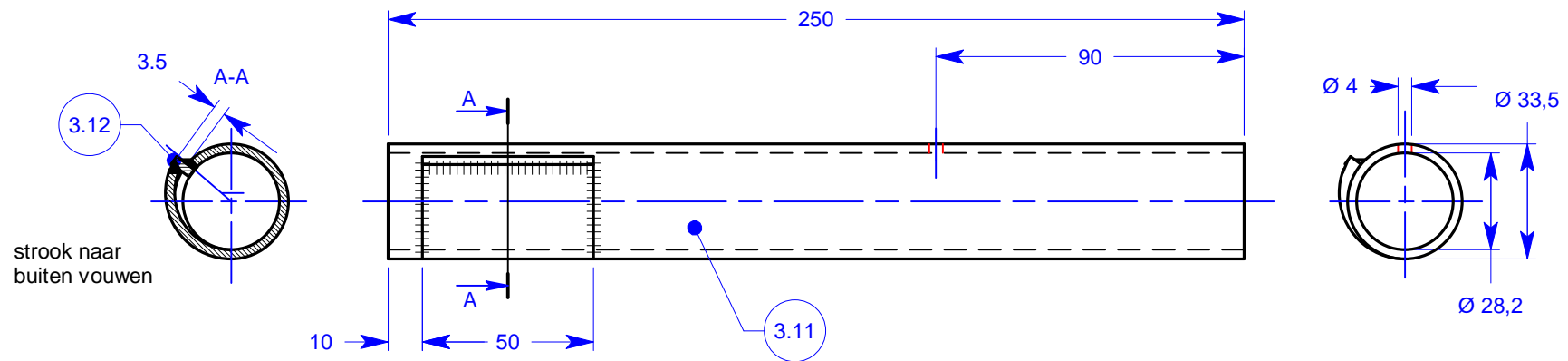

3.13	1	locking needle	2" nail	45 long	remove head & tip
3.12	1	end strip	strip 3 mm thick	50*7	
3.11	1	bushing	pipe class-A 1"	250 long	
Part nr.	Num ber	Part name	Material or semi manufacture	Dimension in mm	Remarks
Project: Flamingo rope pump			Drawn by: Freddy	Date: 21-09-2011	
Drawing: Bushing			Checked by: -		
			Part of: PTP2011/3		
			Drawing nr: PTP2011/3/1		
Scale: 1:2		Dimensions in mm	A4		

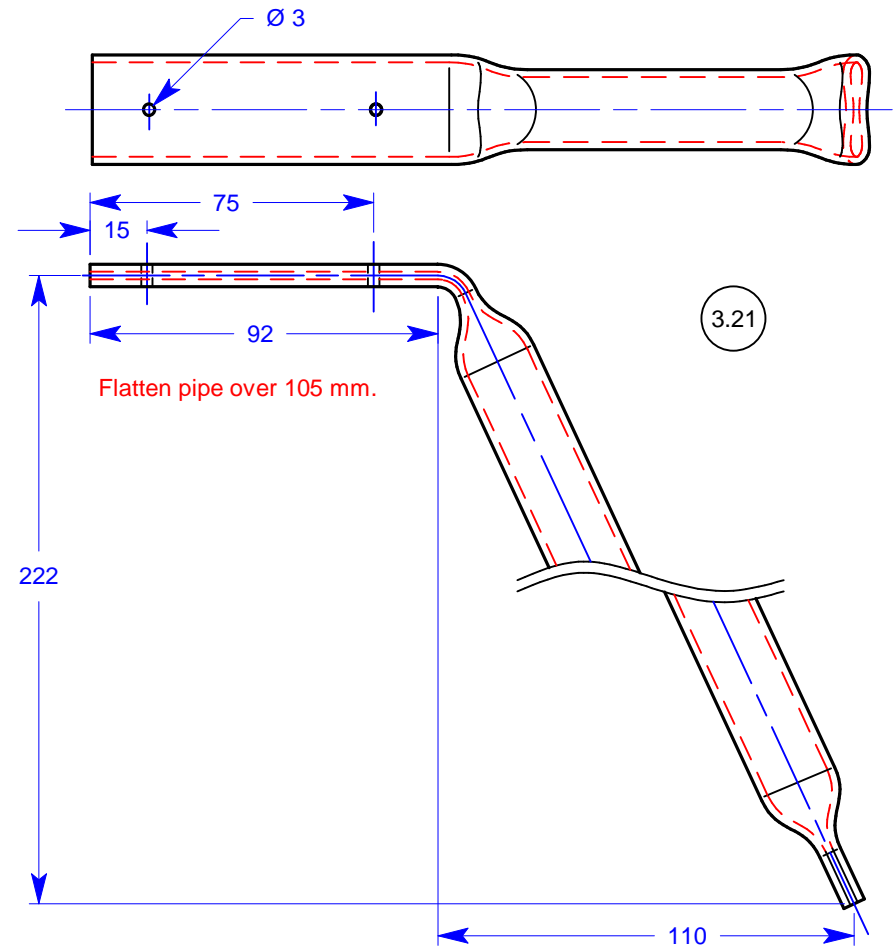
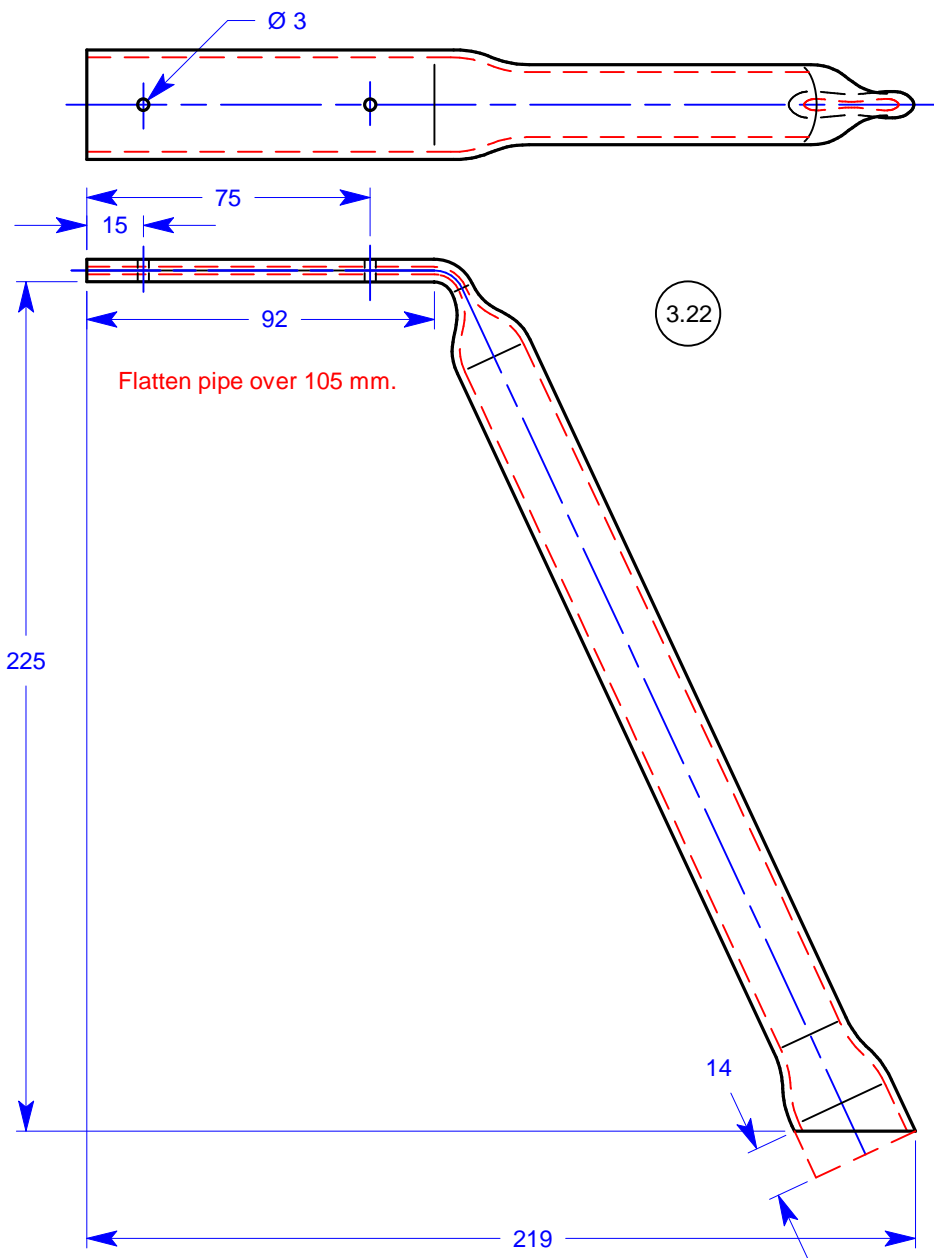

3.22	1	vertical bracket	pipe class-A 1/2"	354 long	
3.21	2	horizontal bracket	pipe class-A 1/2"	345 long	
Part nr.	Number	Part name	Material or semi manufacture	Dimension in mm	Remarks
Project: Flamingo rope pump			Drawn by: Freddy	Date: 21-09-2011	
			Checked by: -		
Drawing: Cover brackets			Part of: PTP2011/3		
			Drawing nr: PTP2011/3/2		
Scale: 1:2			Dimensions in mm	A4	

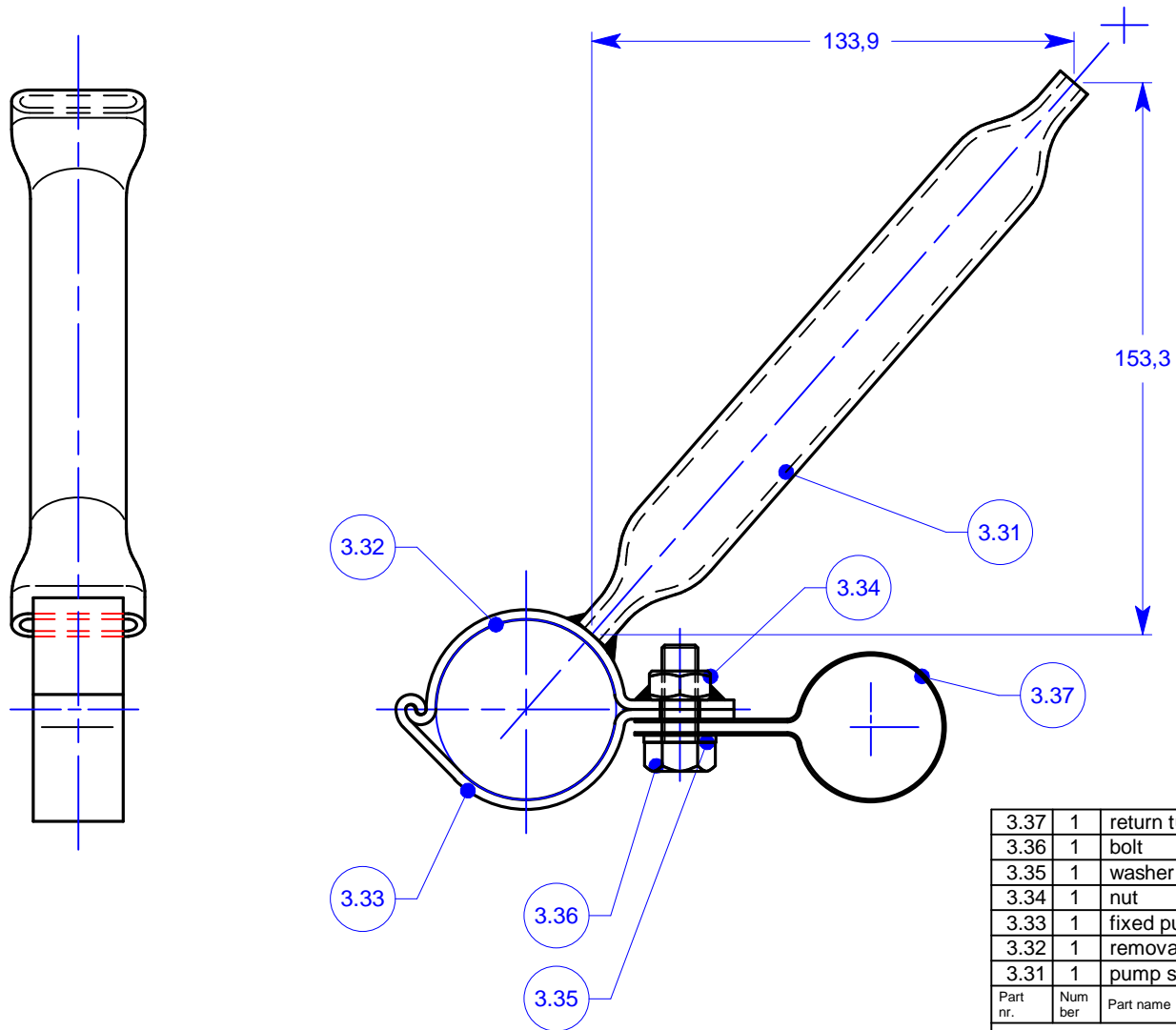

3.37	1	return tube clamp			see PTP2011/3/3/1
3.36	1	bolt	bolt M10*25		
3.35	1	washer	washer M10		
3.34	1	nut	nut M10		
3.33	1	fixed pump clamp			see PTP2011/3/3/1
3.32	1	removable pump clamp			see PTP2011/3/3/1
3.31	1	pump support arm			see PTP2011/3/3/1
Part nr.	Num ber	Part name	Material or semi manufacture	Dimension in mm	Remarks
Project: Flamingo rope pump			Drawn by: Freddy	Date: 21-09-2011	
Drawing: Pump support			Checked by: -		
			Part of: PTP2011/3		
			Drawing nr: PTP2011/3/3		
Scale: 1:2		Dimensions in mm	A4		



Werkgroep OntwikkelingsTechnieken
www.wot.utwente.nl



Universiteit Twente
de ondernemende universiteit

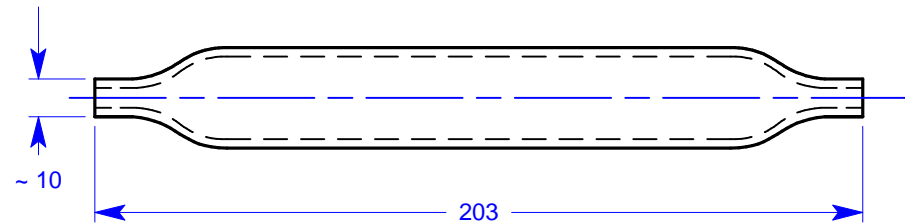
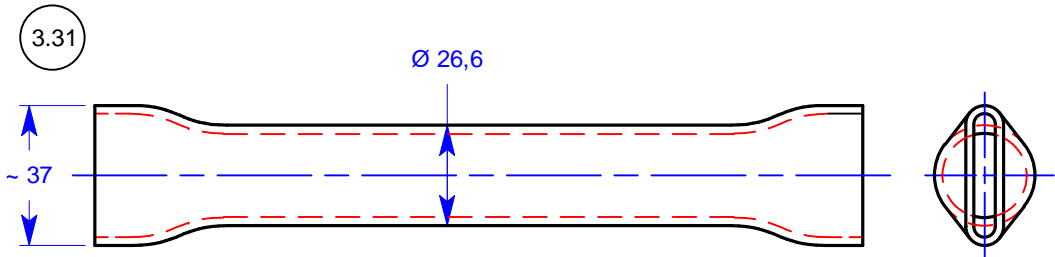
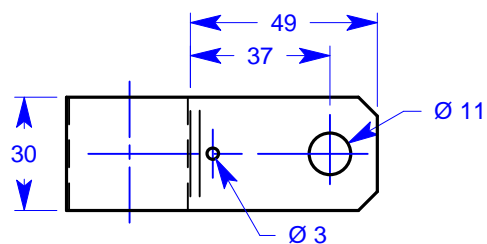
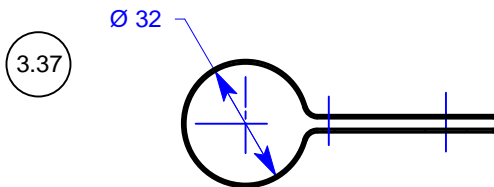
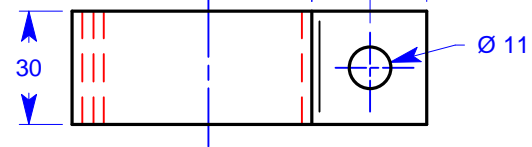
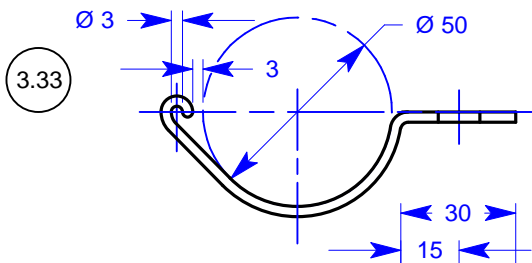
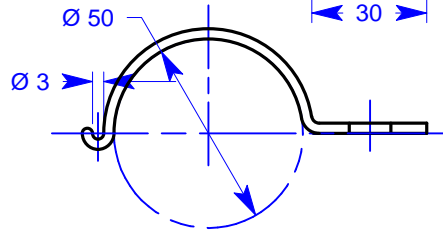
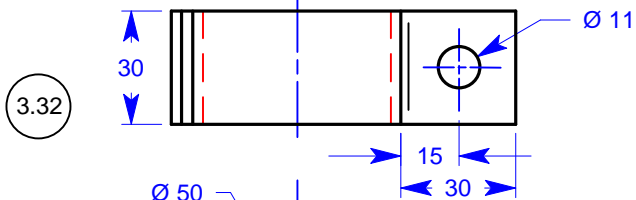

* use unfolded pieces 1¼" pipe if strip is not available.

3.37	1	return tube clamp	galv. sheet 0,7 thick	195*30	
3.33	1	removable pump clamp	strip 30*3	125 long	*
3.32	1	fixed pump clamp	strip 30*3	130 long	*
3.31	1	pump support arm	pipe class-A 3/4 "	203 long	
Part nr.	Num ber	Part name	Material or semi manufacture	Dimension in mm	Remarks
Project: Flamingo rope pump			Drawn by: Freddy	Date: 10-11-2011	
Drawing: Pump support parts			Checked by: -		
			Part of: PTP2011/3/3		
			Drawing nr: PTP2011/3/3/1		
Scale: 1:2			Dimensions in mm	A4	



Werkgroep OntwikkelingsTechnieken
www.wot.utwente.nl

Universiteit Twente
de onderzoekende universiteit

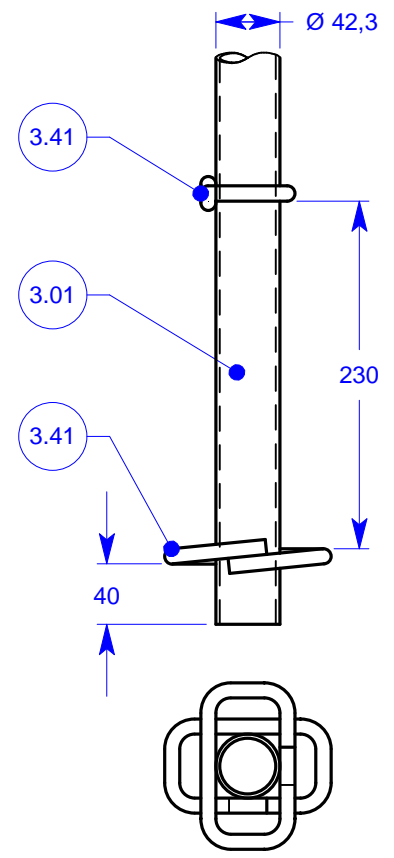
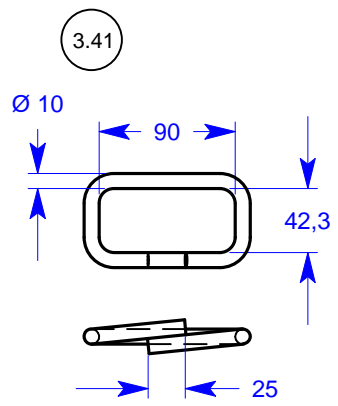
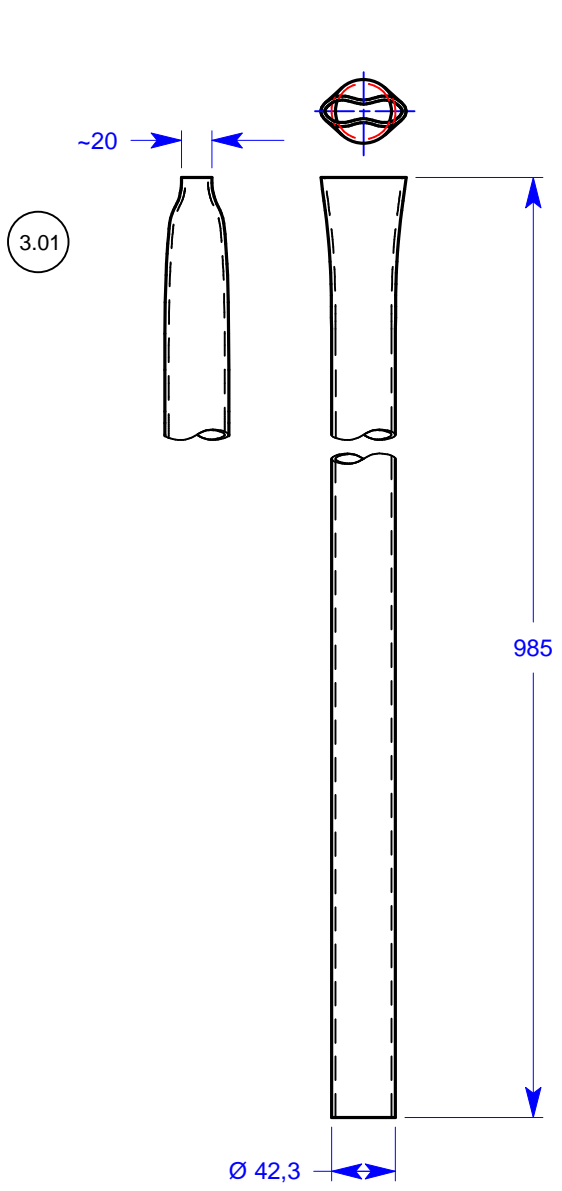

3.41	2	anchor bracket	reinforcing bar Ø10	290 long	
3.01	1	post	pipe class-A 1 1/4"	985 long	
Part nr.	Num ber	Part name	Material or semi manufacture	Dimension in mm	Remarks
Project: Flamingo rope pump			Drawn by: Freddy	Date: 22-09-2011	
Drawing: Anchor bracket			Checked by: -		
			Part of: PTP2011/3		
			Drawing nr: PTP2011/3/4		
Scale: 1:5			Dimensions in mm	A4	

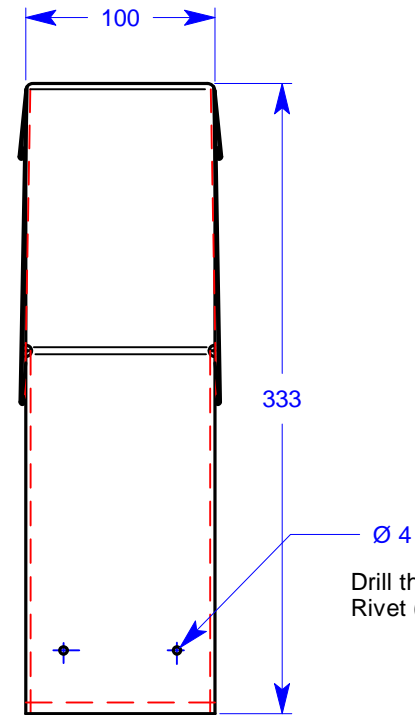
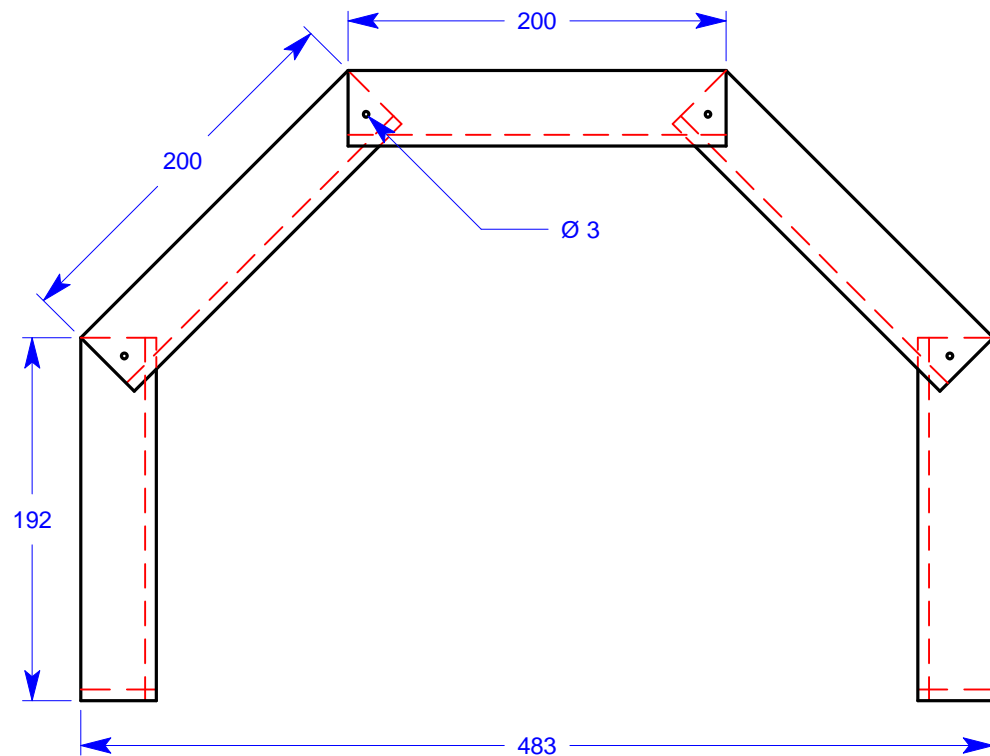

Drill these holes during assembly.
Rivet (4.13) the cover to the frame.

4.13	4	pop rivet	pop rivet Ø4*10		
4.12	8	pop rivet	pop rivet Ø3*8		
4.11	1	cover sheet			see PTP2011/4/1
Part nr.	Num ber	Part name	Material or semi manufacture	Dimension in mm	Remarks
Project: Flamingo rope pump			Drawn by: Freddy	Date: 21-09-2011	
Drawing: Cover			Checked by: -		
			Part of: PTP2011		
			Drawing nr: PTP2011/4		
Scale: 1:4			Dimensions in mm	A4	



Werkgroep OntwikkelingsTechnieken
www.wot.utwente.nl



Universiteit Twente
de ondernemende universiteit

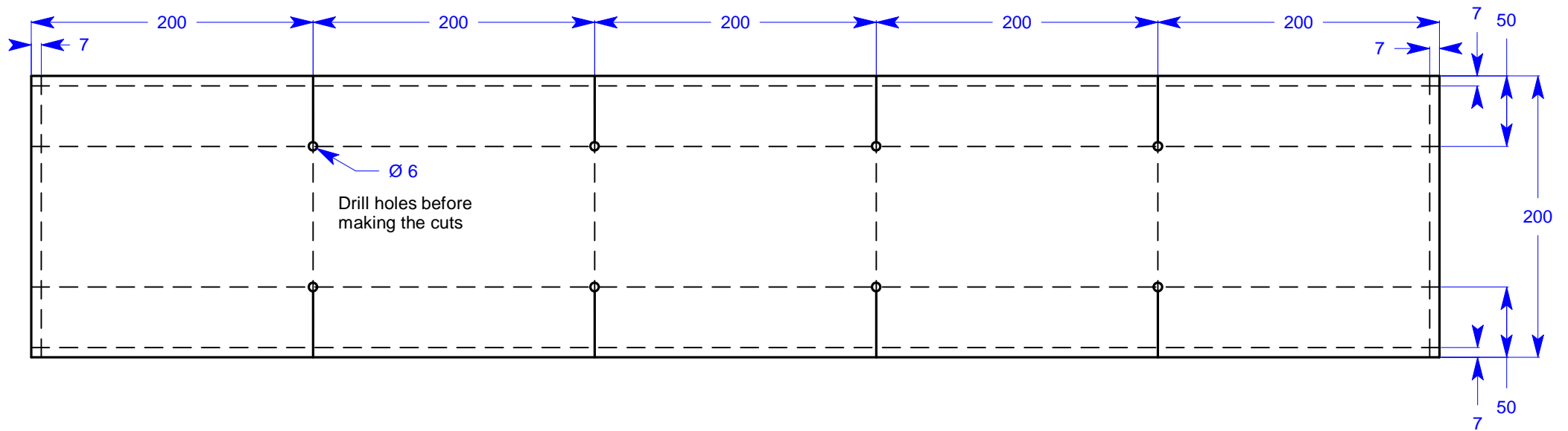

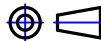
4.11	1	cover sheet	galv. sheet 0,7 thick	200*1000	
Part nr.	Number	Part name	Material or semi manufacture	Dimension in mm	Remarks
Project: Flamingo rope pump			Drawn by: Freddy	Date: 21-09-2011	
Drawing: Cover sheet			Checked by: -	Part of: PTP2011/4	
Scale: 1:4			Drawing nr: PTP2011/4/1		A4
			 Dimensions in mm		



Werkgroep OntwikkelingsTechnieken
www.wot.utwente.nl



Universiteit Twente
de ondernemende universiteit

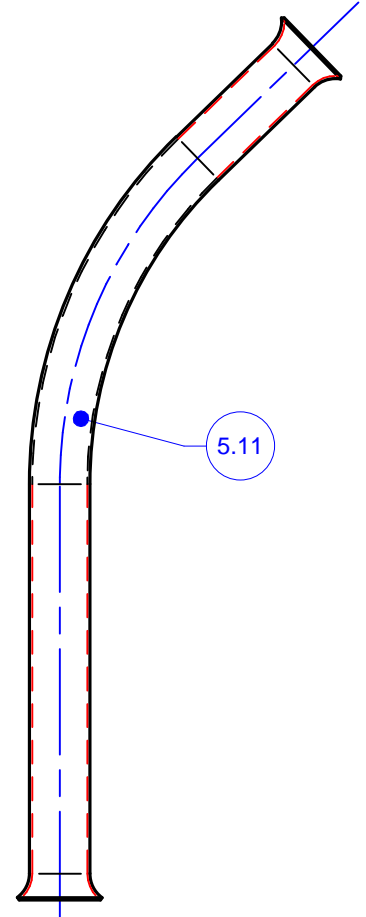
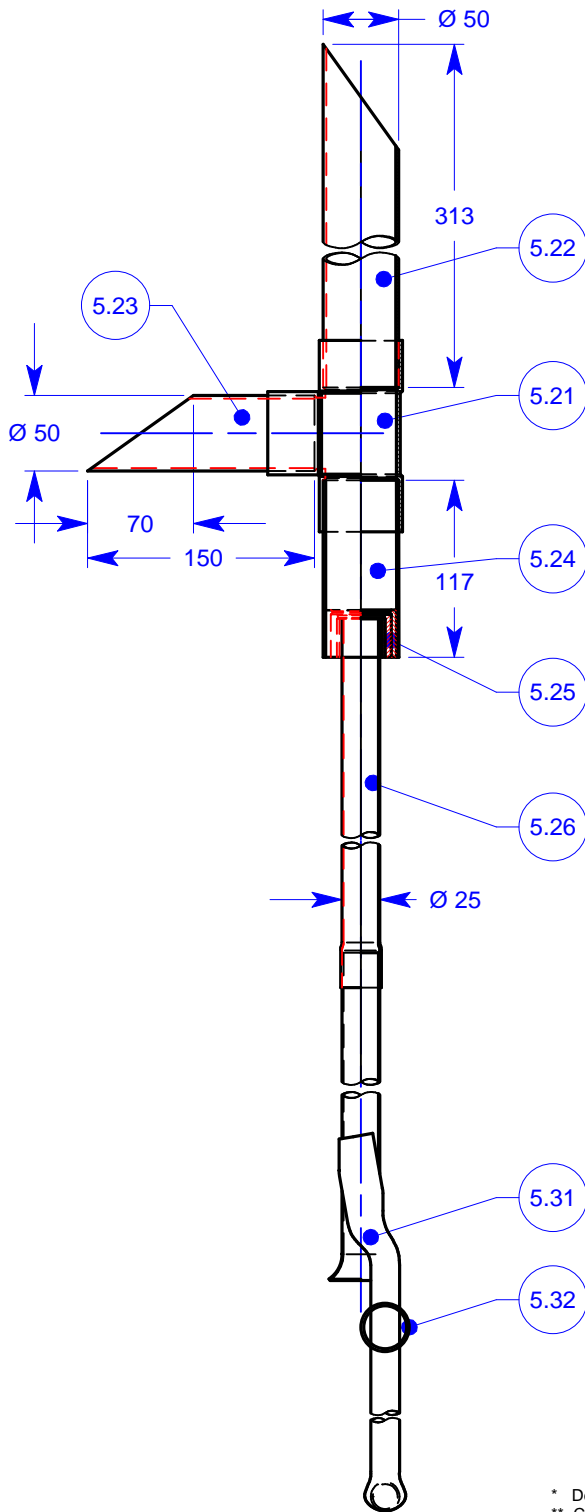

* Depending on groundwater level
 ** Composed with various dimensions PVC-tube
 *** Must be long enough for reaching over the concrete block

5.32	1	rope guide			see PTP2011/5/3
5.31	1	inlet guide			see PTP2011/5/3
5.26	*	rising main	*		
5.25	1	reducer 25-48.2	**	30 long	
5.24	1	coupling tube	PVC-tube Ø50*1.8	117 long	
5.23	1	outlet tube	PVC-tube Ø50*1.8	150 long ***	
5.22	1	top tube	PVC-tube Ø50*1.8	313 long	
5.21	1	t-joint	PVC T-joint 50*50*50		
5.11	1				zie PTP2011/5/1
Part nr.	Number	Part name	Material or semi manufacture	Dimension in mm	Remarks
Project: Flamingo rope pump			Drawn by: Freddy	Date: 27-09-2011	
Drawing: Pump assembly			Checked by: -		
			Part of: PTP2011		
			Drawing nr: PTP2011/5		
Scale:	1:5		Dimensions in mm		A4

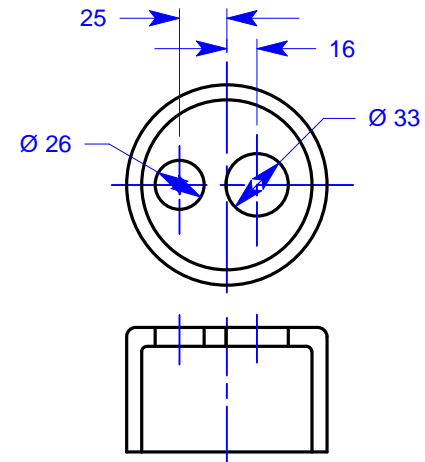
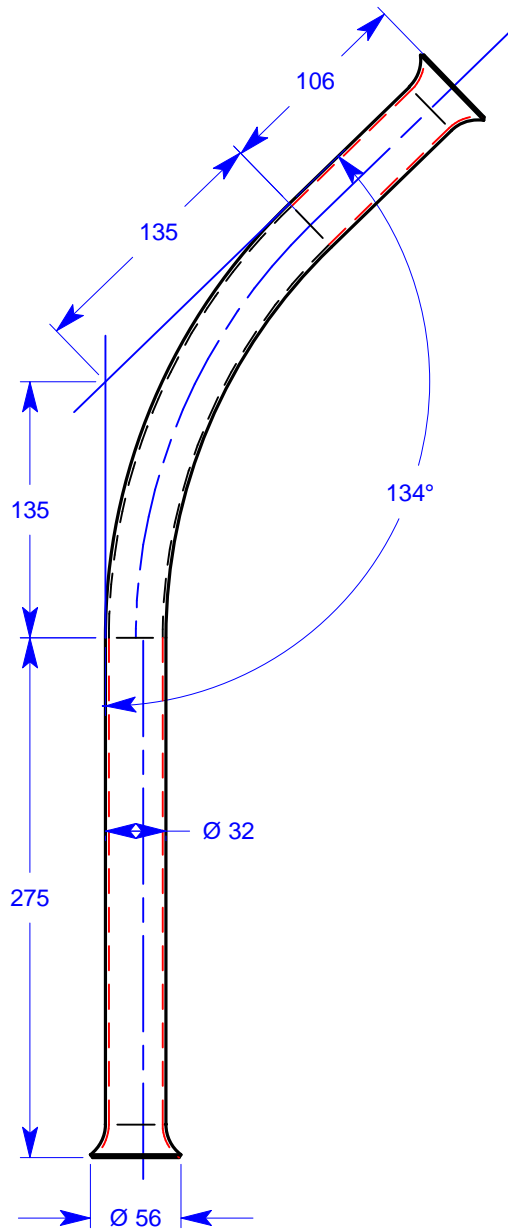

5.12	1	borehole cover	end cap for borehole		
5.11	1	return tube	PVC-tube Ø40	620 long	
Part nr.	Num ber	Part name	Material or semi manufacture	Dimension in mm	Remarks
Project: Flamingo rope pump			Drawn by: Freddy	Date: 28-09-2011	
			Checked by: -		
Drawing: Return tube			Part of: PTP2011		
			Drawing nr: PTP2011/5/1		
Scale: 1:4		Dimensions in mm			
					A4



Werkgroep OntwikkelingsTechnieken
www.wot.utwente.nl



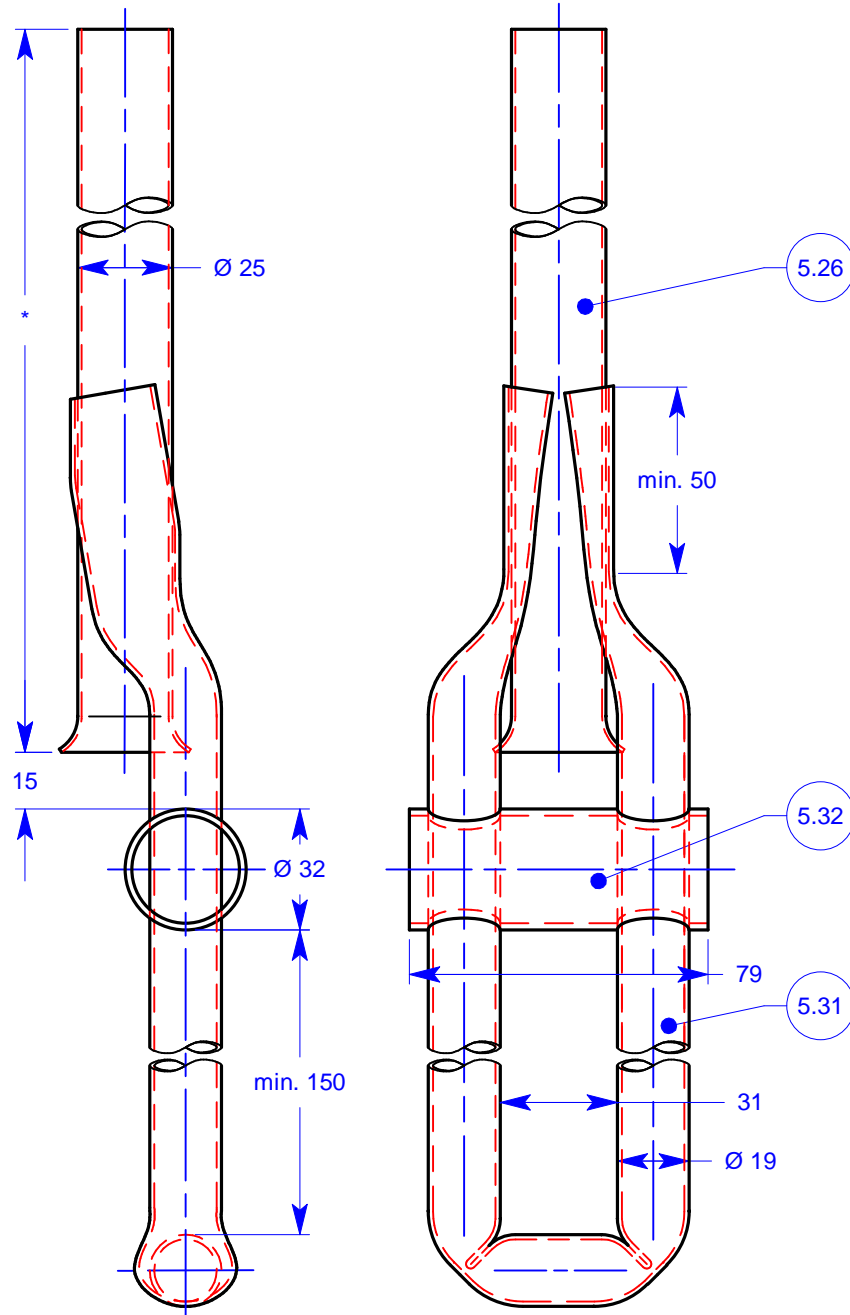

Part nr.	Num ber	Part name	Material or semi manufacture	Dimension in mm	Remarks
5.31	1	inlet guide	PVC-tube Ø19	670 long	electro installation tube
5.32	1	rope guide	PVC-tube Ø32*1.8	79 long	
5.26	1	rising main	PVC-tube Ø25*1	* long	flare lower end
Project: Flamingo rope pump			Drawn by: Freddy	Date: 27-09-2011	
Drawing: Inlet guide 25 mm			Checked by: -	Part of: PTP2011/5	
Scale: 1:2			Drawing nr: PTP2011/5/3		

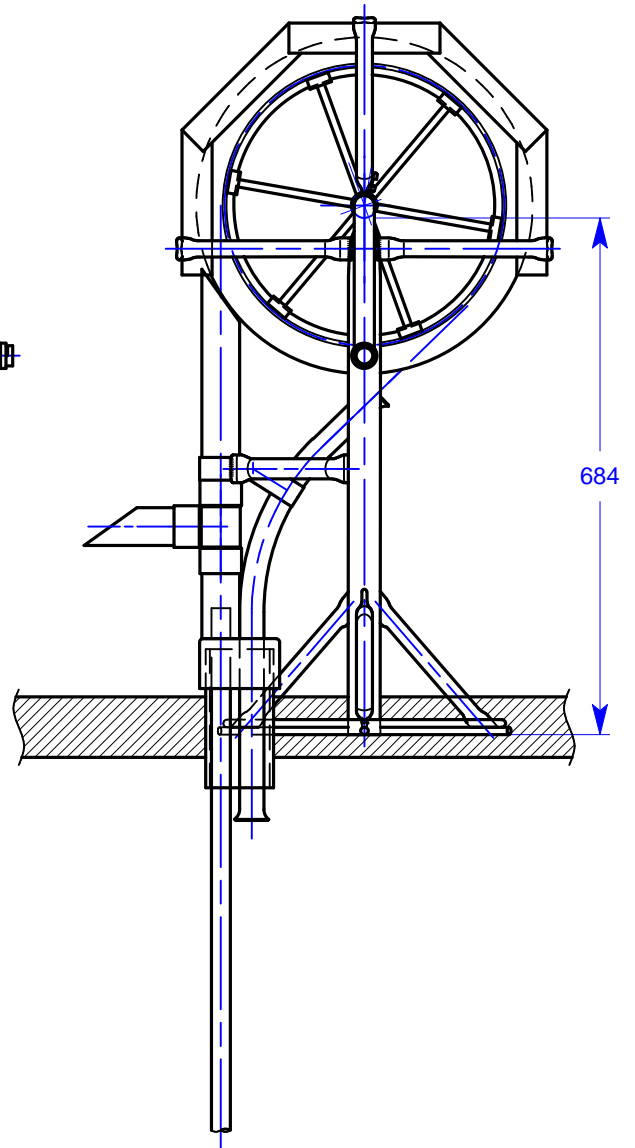
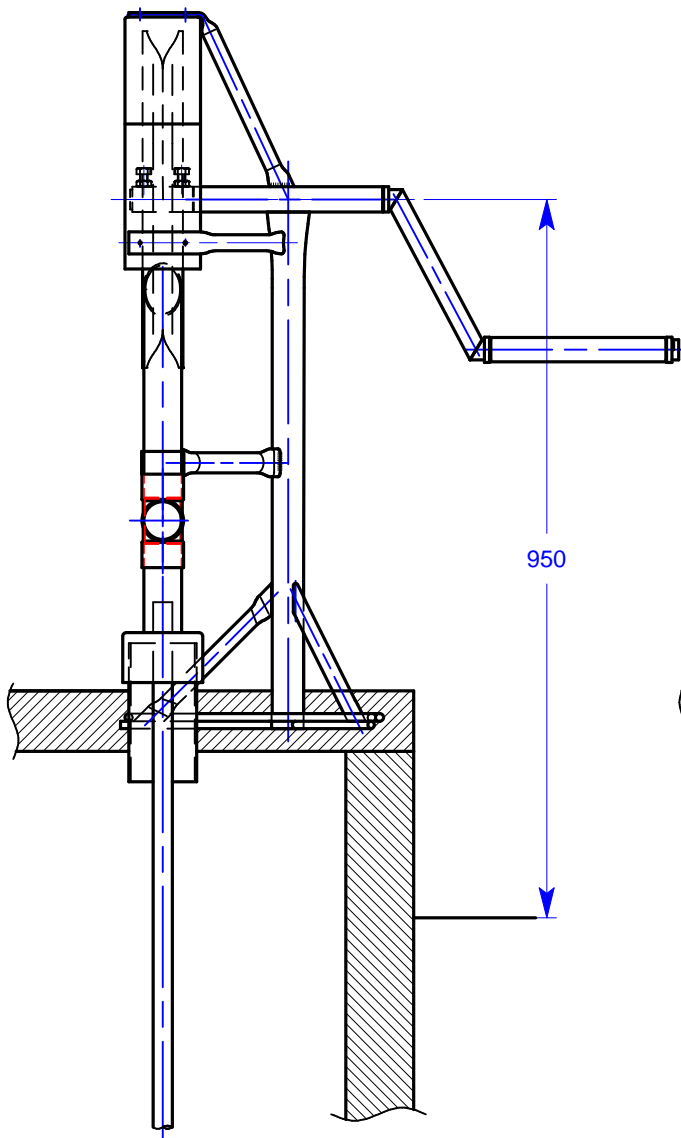
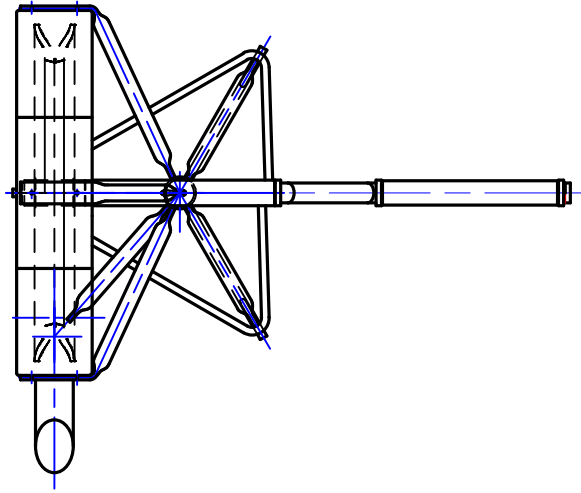

Part nr.	Num ber	Part name	Material or semi manufacture	Dimension in mm	Remarks
Project: Flamingo rope pump			Drawn by: Freddy	Date: 27-09-2011	
Drawing: Well cover model			Checked by: -		
			Part of: -		
			Drawing nr: PTP2011b (optional)		
Scale: 1:10			Dimensions in mm	A4	
WOT			Werkgroep OntwikkelingsTechnieken www.wot.utwente.nl		Universiteit Twente <i>de ondernemende universiteit</i>

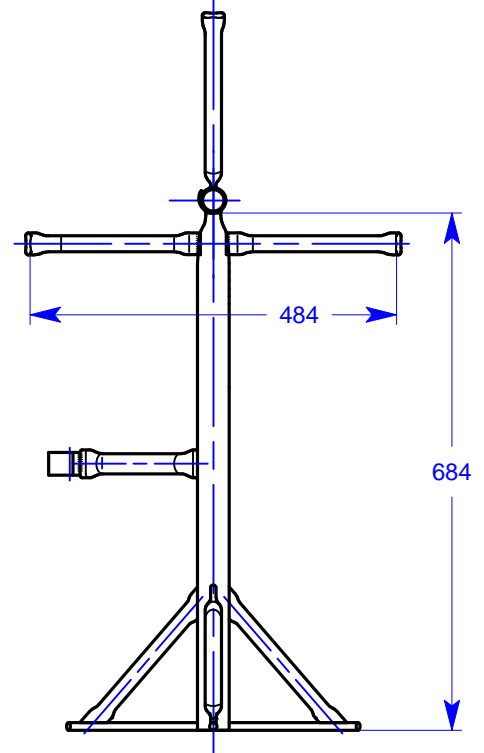
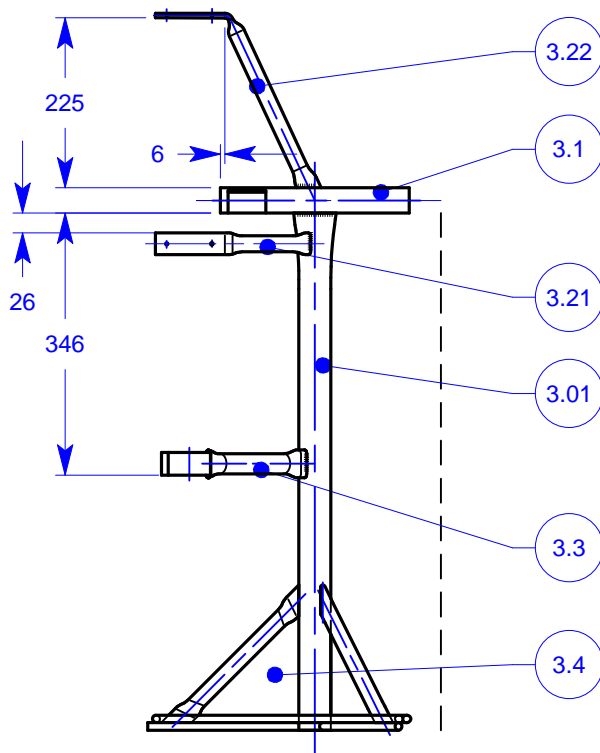
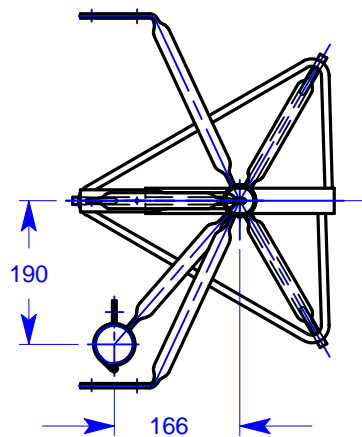

3.4	1	anchor base			see PTP2011b/3/4
3.3	1	pump support			see PTP2011/3/3
3.22	1	verticale bracket			see PTP2011/3/2
3.21	2	horizontal bracket			see PTP2011/3/2
3.1	1	bushing			see PTP2011/3/1
3.01	1	post			see PTP2011b/3/4
Part nr.	Number	Part name	Material or semi manufacture	Dimension in mm	Remarks
Project: Flamingo rope pump			Drawn by: Freddy	Date: 27-09-2011	
Drawing: Frame well cover			Checked by: -		
			Part of: PTP2011b (optional)		
			Drawing nr: PTP2011b/3 (optional)		
Scale:	1:10		Dimensions in mm		
					A4

To clarify the anchor triangle 3.44 is hidden drawn.

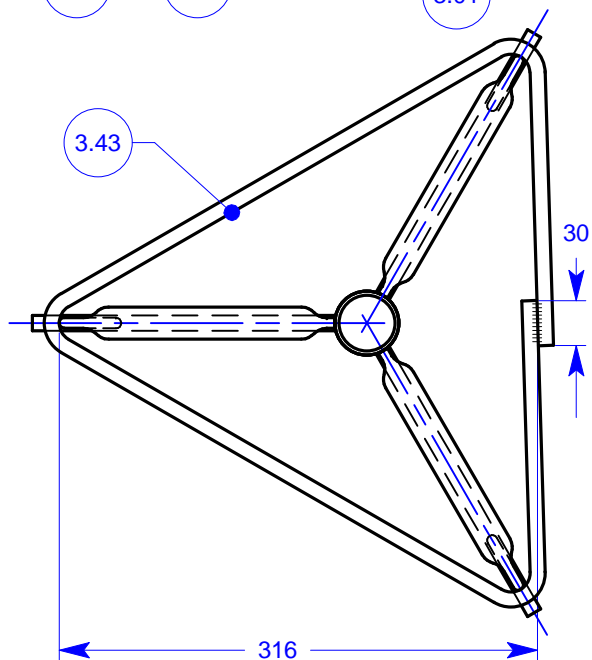
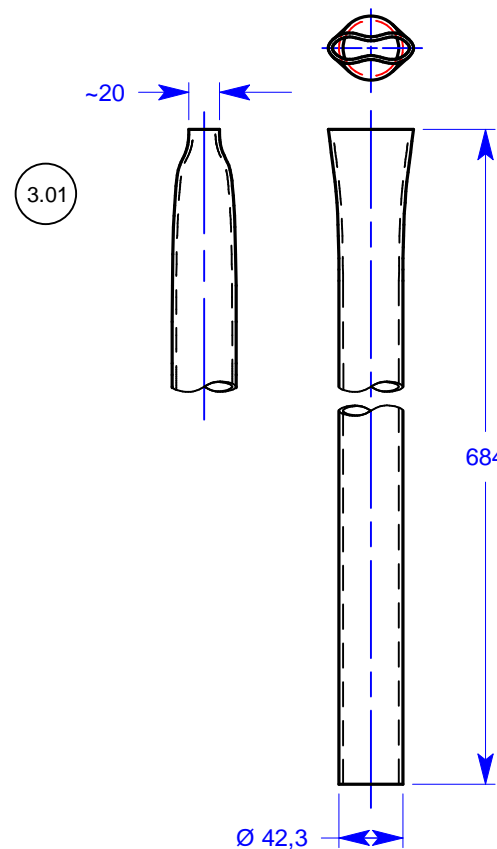
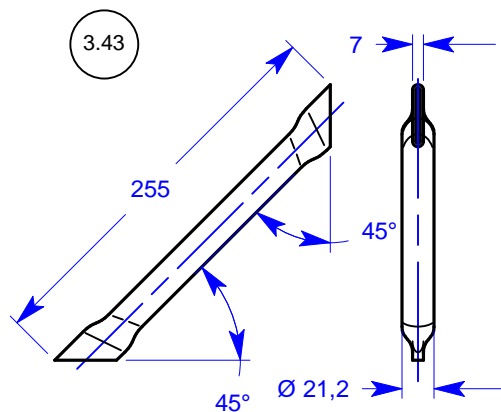
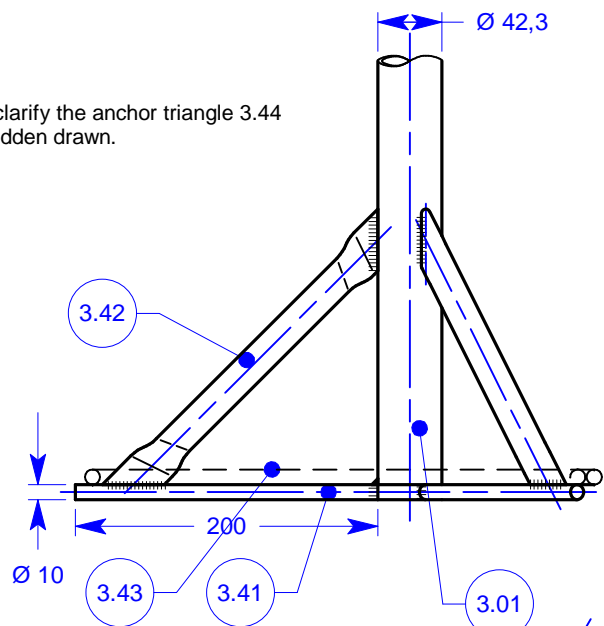

3.44	1	anchor triangle	reinforcing bar Ø10	1130 long	
3.43	3	anchor support	pipe class-A 1/2"	255 long	
3.42	3	anchoring bar	reinforcing bar Ø10	200 long	
3.01	1	post	pipe class-A 1 1/4"	684 long	
Part nr.	Num ber	Part name	Material or semi manufacture	Dimension in mm	Remarks
Project: Flamingo rope pump			Drawn by: Freddy	Date: 27-09-2011	
Drawing: Anchor base			Checked by: -		
			Part of: PTP2011b/3 (optional)		
			Drawing nr: PTP2011b/3/4 (optional)		
Scale: 1:5			Dimensions in mm	A4	



Werkgroep OntwikkelingsTechnieken
www.wot.utwente.nl

Universiteit Twente
de ondernemende universiteit

Part list Flamingo Rope Pump PTP2011

- Welding Jigs -

drawing name	drawing nr	part nr.	number	part name	material or semi manufacture	dimension in mm	remarks
wheel welding jig	PTP2011/m1	m1.1	1	mounting plate	galva. sheet 5 mm dik	150*150	
wheel welding jig	PTP2011/m1	m1.2	1	center post	pipe class-A 3/4"	80 long	
wheel welding jig	PTP2011/m1	m1.3	6	spoke	angle iron 25*25*3	135 long	
wheel welding jig	PTP2011/m1	m1.4	6	tire clamp	strip 25*3	38 long	
wheel welding jig	PTP2011/m1	m1.5	1	hold clamp	angle iron 25*25*3	100 long	
handle jig	PTP2011/m2	m2.1	1	handle jig	wood slab 18 mm thick	270*605	
bushing jig	PTP2011/m3	m3.1	1	post guide	angle iron 25*25*3	290 long	
bushing jig	PTP2011/m3	m3.2	1	pipe guide	angle iron 25*25*3	79 long	
bushing jig	PTP2011/m3	m3.3	1	diagonal	angle iron 25*25*3	105 ong	
bushing jig	PTP2011/m3	m3.4	1	post clamp	angle iron 25*25*3	80 long	
bushing jig	PTP2011/m3	m3.5	1	pipe clamp	angle iron 25*25*3	80 long	
bushing jig	PTP2011/m3	m3.6	2	clamp bracket	threaded rod	185 long	
bushing jig	PTP2011/m3	m3.7	4	winged nut	winged nut M10		
cover bracket jig	PTP2011/m4	m4.1	1	horizontal beam	angle iron 25*25*3	477 long	
cover bracket jig	PTP2011/m4	m4.2	1	vertical beam	angle iron 25*25*3	312 long	
cover bracket jig	PTP2011/m4	m4.3	3	bracket support	angle iron 25*25*3	80 long	
cover bracket jig	PTP2011/m4	m4.4	1	bracket hold	angle iron 25*25*3	25 long	
cover bracket jig	PTP2011/m4	m4.5	1	stiffener plate	strip 10*3	25 long	from angle iron
cover bracket jig	PTP2011/m4	m4.6	1	center pipe	pipe class-A 3/4"	265 long	
cover bracket jig	PTP2011/m4	m4.7	1	nut	nut M10		
cover bracket jig	PTP2011/m4	m4.8	1	washer	washer M10		outer diameter 30 mm
cover bracket jig	PTP2011/m4	m4.9	1	bolt	bolt M10*25		

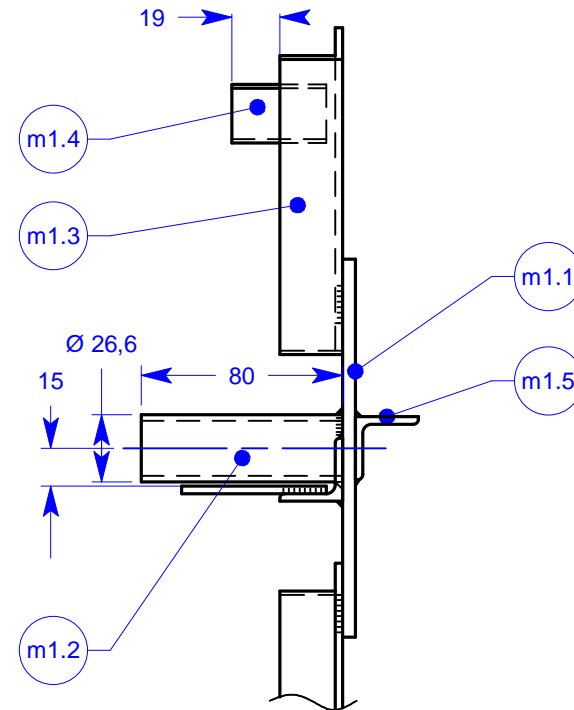
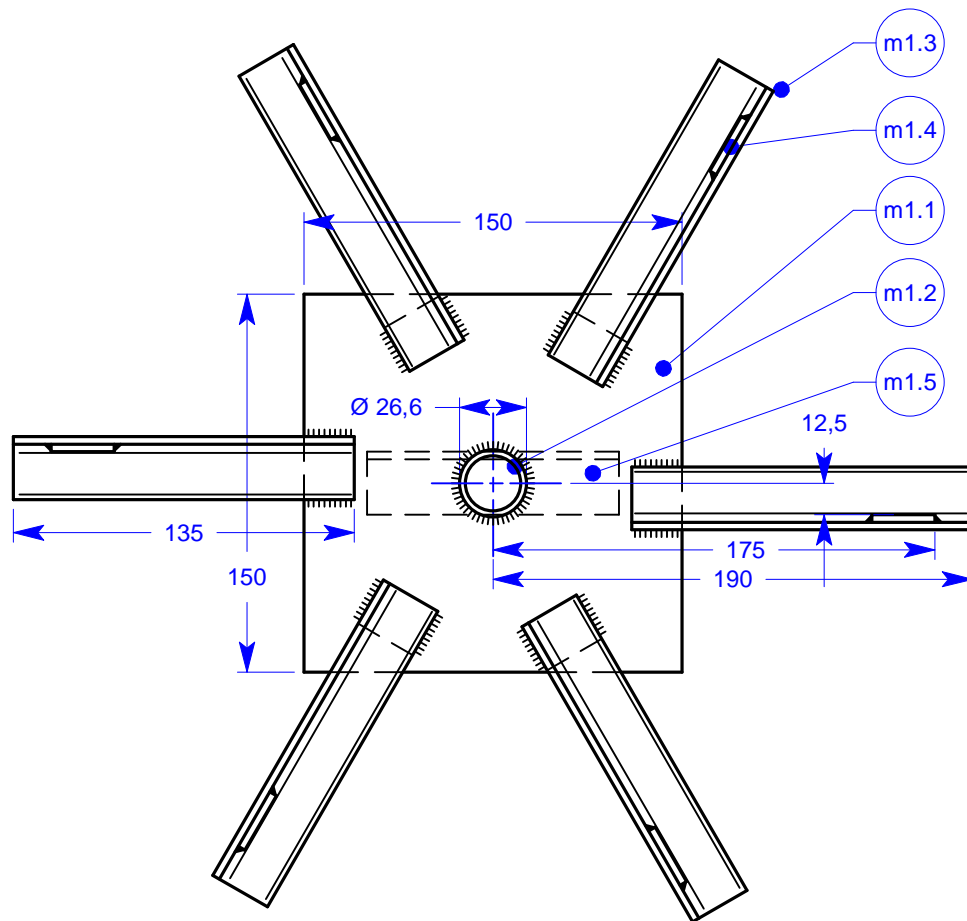

m1.5	1	hold clamp	angle iron 25*25*3	100 long	
m1.4	6	tire clamp	strip 25*3	38 long	
m1.3	6	spoke	angle iron 25*25*3	135 long	
m1.2	1	center post	pipe class-A 3/4 "	80 long	
m1.1	1	mounting plate	steel sheet 5 mm thick	150*150	
Part nr.	Num ber	Part name	Material or semi manufacture	Dimension in mm	Remarks
Project: Flamingo rope pump			Drawn by: Freddy	Date: 05-10-2011	
Drawing: Wheel welding jig			Checked by: -		
			Part of: PTP2011		
			Drawing nr: PTP2011/m1		
Scale: 1:3		Dimensions in mm			

A4



Werkgroep OntwikkelingsTechnieken
www.wot.utwente.nl



Universiteit Twente
de ondernemende universiteit

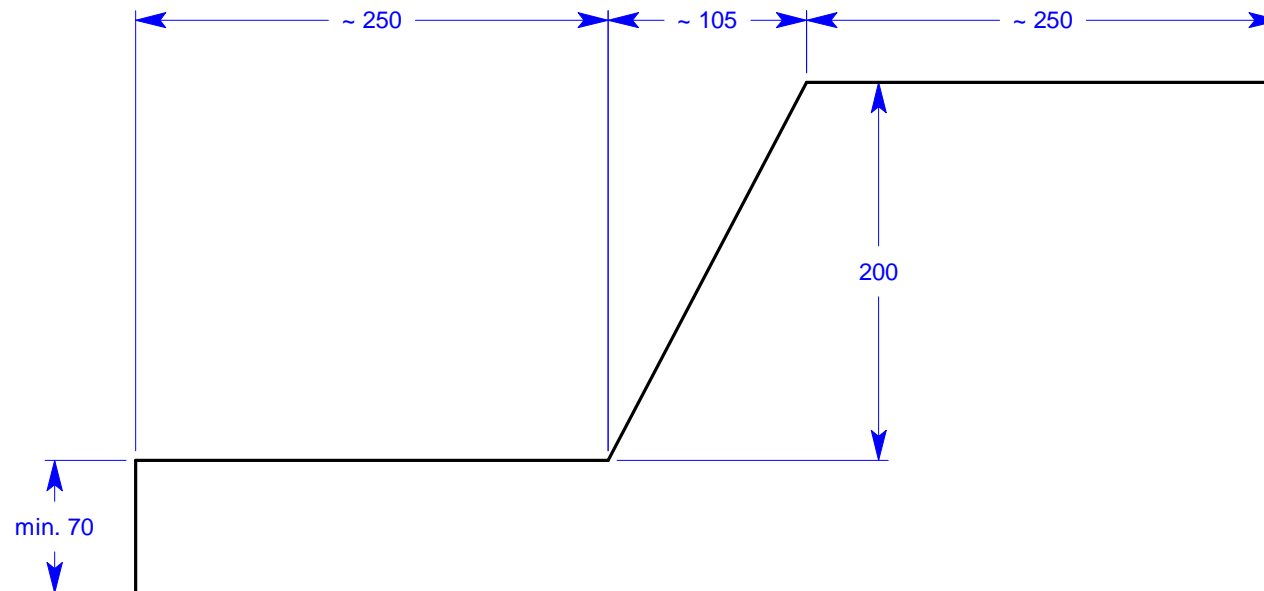

m2.1	1	handle jig	wood slab 18 mm thick	270*605	
Part nr.	Num ber	Part name	Material or semi manufacture	Dimension in mm	Remarks
Project: Flamingo rope pump			Drawn by: Freddy	Date: 02-10-2011	
Drawing: Handle jig			Checked by: -		
			Part of: PTP2011/		
			Drawing nr: PTP2011/m2		
Scale: 1:4			Dimensions in mm	A4	



Werkgroep OntwikkelingsTechnieken
www.wot.utwente.nl



Universiteit Twente
de ondernemende universiteit

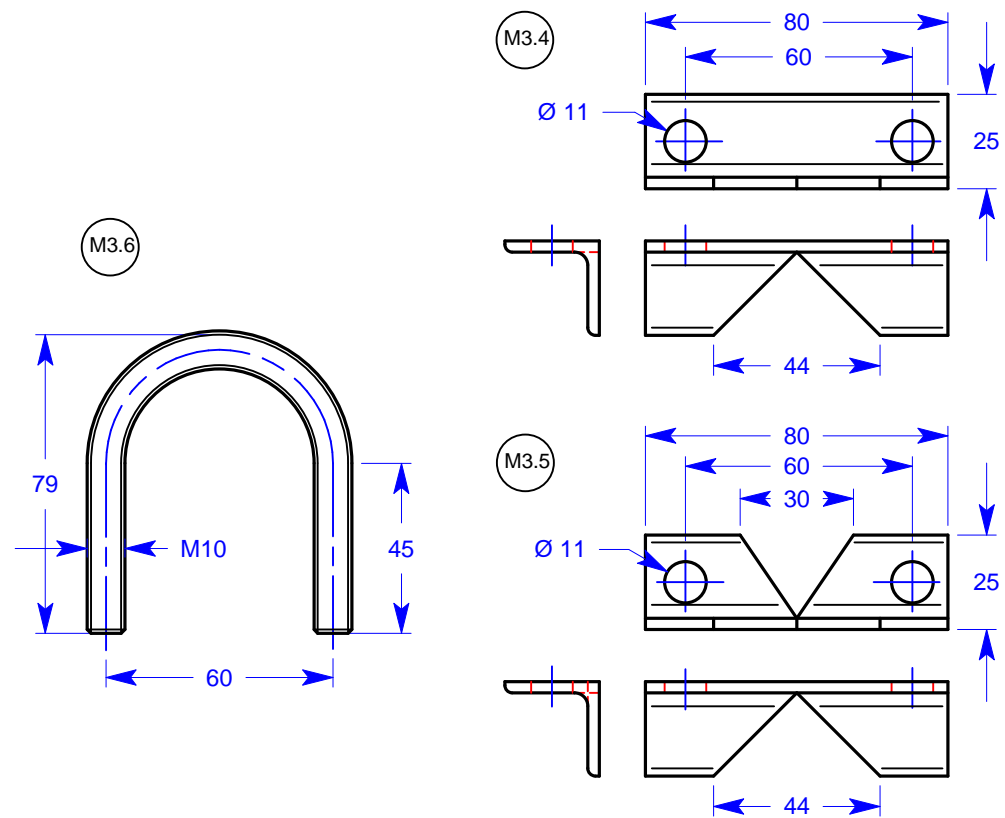
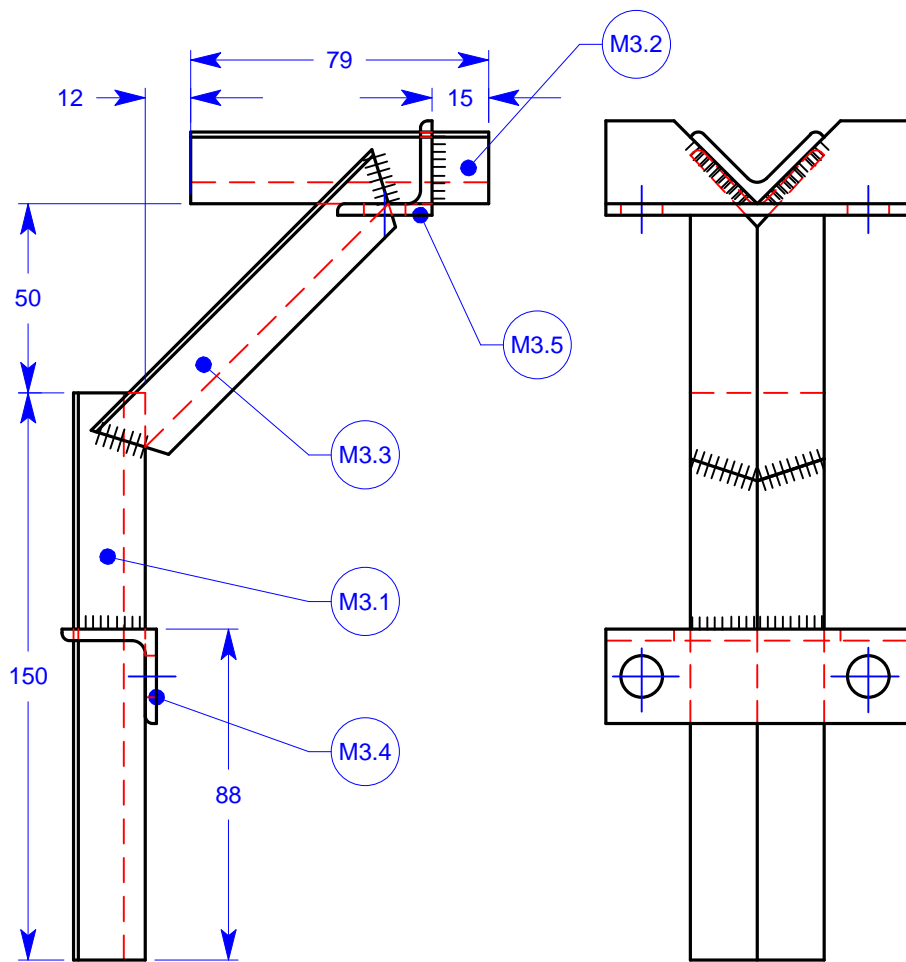

m3.7	4	winged nut	winged nut M10		
m3.6	2	clamp bracket	threaded rod M10	185 long	
m3.5	1	pipe clamp	angle iron 25*25*3	80 long	
m3.4	1	post clamp	angle iron 25*25*3	80 long	
m3.3	1	diagonal	angle iron 25*25*3	105 long	
m3.2	1	pipe guide	angle iron 25*25*3	79 long	
m3.1	1	post guide	angle iron 25*25*3	290 long	

Part nr.	Num ber	Part name	Material or semi manufacture	Dimension in mm	Remarks
----------	---------	-----------	------------------------------	-----------------	---------

Project: Flamingo rope pump
 Drawn by: Freddy
 Date: 18-11-2011

Drawing: Frame angle jig
 Part of: PTP2011/
 Drawing nr: PTP2011/m3

Scale: 1:2
 Dimensions in mm
 A4

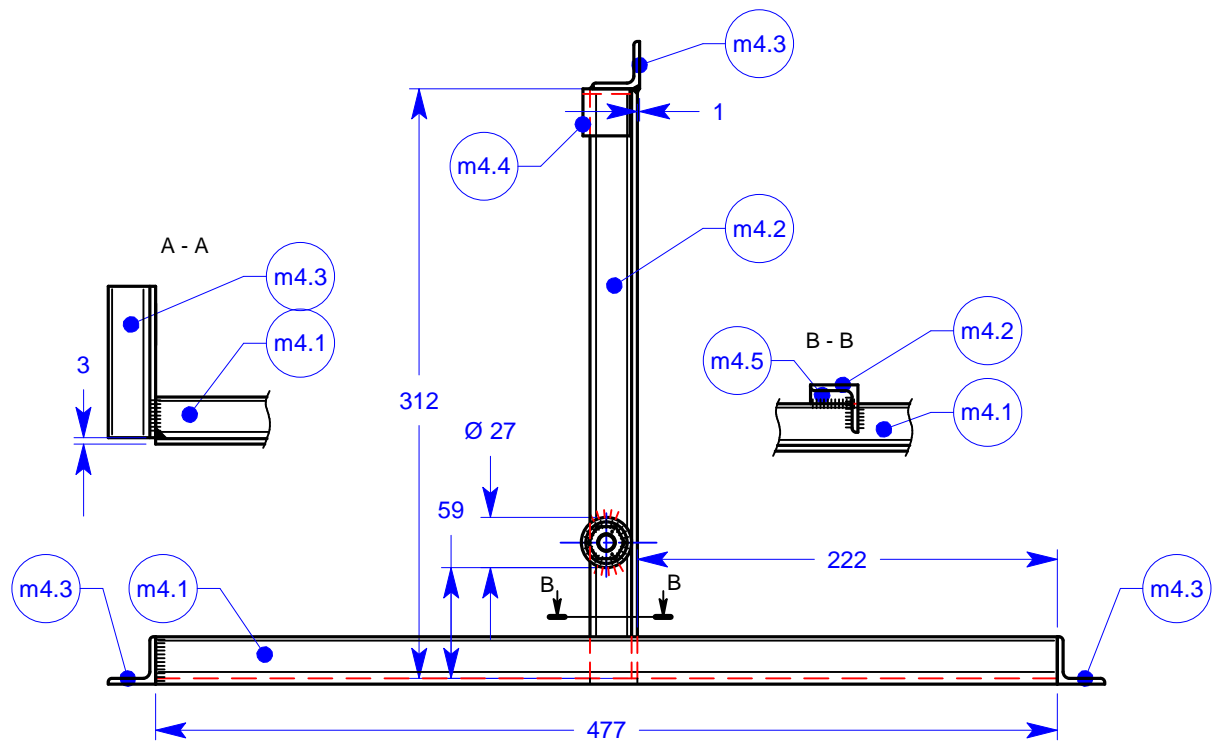
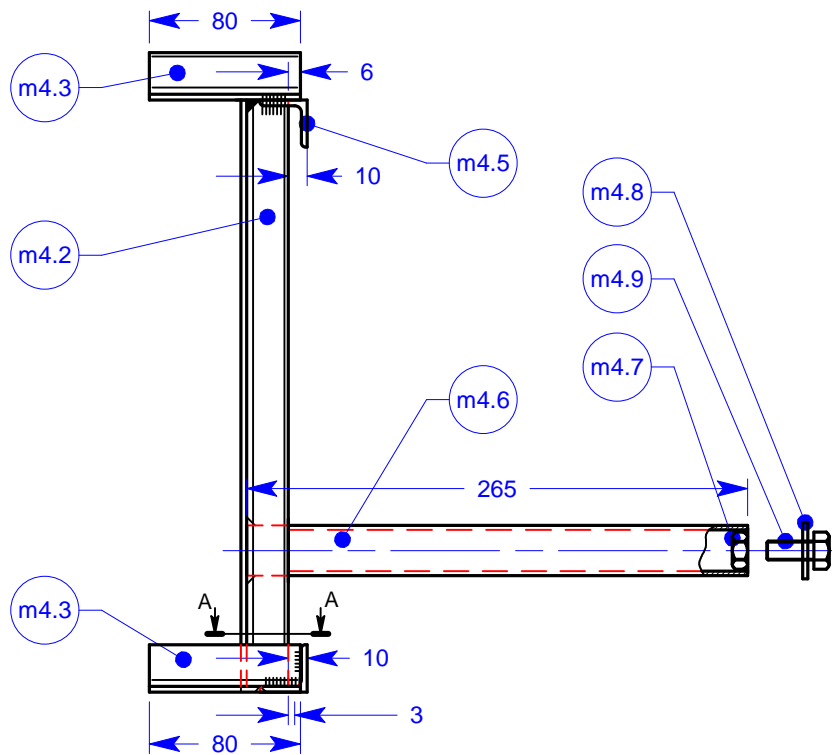

m4.9	1	bolt	bolt M10*25		
m4.8	1	washer	washer M10		outer diameter 30 mm
m4.7	1	nut	nut M10		
m4.6	1	center pipe	pipe class-A 3/4"	265 long	
m4.5	1	stiffener plate	strip 10*3	25 long	from angle iron
m4.4	1	bracket hold	angle iron 25*25*3	25 long	
m4.3	3	bracket support	angle iron 25*25*3	80 long	
m4.2	1	vertical beam	angle iron 25*25*3	312 long	
m4.1	1	horizontal beam	angle iron 25*25*3	477 long	
Part nr.	Num ber	Part name	Material or semi manufacture	Dimension in mm	Remarks

Project: Flamingo rope pump
 Drawn by: Freddy
 Date: 16-11-2011
 Checked by: -

Drawing: Cover bracket jig
 Part of: PTP2011/
 Drawing nr: PTP2011/m4

Scale: 1:4
 Dimensions in mm
 A4